

FIRST FLIGHT



G-Wiz

HCX

Learning to Use Your G-Wiz HCX Flight Computer

Version 1.0

Limited Warranty and Disclaimer

G-Wiz Partners warrants the G-Wiz HCX Flight Computers to be free from defects in materials and workmanship and remain in working order for a period of 180 days. If the unit fails to operate as specified, the unit will be repaired or replaced at the discretion of G-Wiz Partners, providing the unit has not been damaged, modified, or serviced by anyone except for the manufacturer.

G-Wiz HCX Flight computers are sold as an experimental accessory only. Due to the nature of experimental electronic devices, especially when used in experimental carriers such as rockets, the possibility of failure can never totally be removed. The owners, employees, vendors and contractors of G-Wiz Partners shall not be liable for any special, incidental, or consequential damage or expense directly or indirectly arising from the customer or anyone's use, misuse, or inability to use this device either separately or in combination with other equipment or for personal injury or loss or destruction of other property, for experiment failure, or for any other cause. It is up to the user, the experimenter, to use good judgment and safe design practices and to properly pre-test the device for its intended performance in the intended vehicle. It is the user or experimenter's responsibility to assure the vehicle will perform in a safe manner and that all reasonable precautions are exercised to prevent injury or damage to anyone or anything.

WARNING: Do not use this device unless you completely understand and agree with all the above statements and conditions. First time use of the G-Wiz HCX Flight Computer signifies the user's acceptance of these terms and conditions.

How to contact G-Wiz Partners

Please see our website at: <http://www.gwiz-partners.com>. Our web site has the latest versions of all our user manuals, device firmware, and FlightView software updates, as well as email contact information.

© 2008 by Marjorie Lynch-Freshner and G-Wiz Partners
Photographs © 2008 by David Randall

Important Safety Precautions

Use a checklist when you set up your flight computer and when you mount it in your rocket.

Dangers from ejection charges – Make safe the ejection charges, or disconnect the power whenever you transport the flight-prepped unit.

Electrostatic discharge - Static electricity can damage or destroy components on your flight computer. Keep it in an antistatic bag when not in use. Ground yourself before handling the flight computer. Be especially cautious when using it in low humidity environments.

The flight computer must be mounted in the correct orientation to operate. The “nose” end is indicated on the board, but to confirm the orientation, make sure the terminal block is at the aft, or rear end of the flight computer.

Make sure the flight computer is rigidly installed in the rocket payload bay.

The computer must be protected from ejection gasses. Ejection gasses are corrosive and will damage the flight computer. Damage from ejection gasses will void your warranty.

Use good batteries – We recommend using Duracell batteries if you are using non-rechargeable batteries. Many lower cost batteries have press fit contacts. Vibration and sudden acceleration can cause these contacts to come loose, resulting in an open circuit during flight. This momentary or permanent break in your power connection **will** cause a catastrophic flight failure. Similarly, make sure your batteries are properly secured to prevent them from pulling wires out of the terminal block pins.

Recommended Battery Sizes:

	Minimum	Optimum	Maximum
CPU	7.5 volt	9 volt	12 volt
Pyro	7.5 volt	9 volt	15 volt

- Using too small a battery can cause a low voltage failure and **will** reduce your operating time and risk a low-voltage failure.
- Using too large a battery on the Pyro circuit has the potential of damaging the MOSFET switches, due to excessive current flow.

Do not mix uses on the Mini-SD memory card. The flight computer needs large **continuous** blocks of memory space on the card to record your flight data. If you use your flight computer’s Mini-SD card for other uses, it will quickly become fragmented and unable to allocate the required space. At that point, you will get a power-on self-test error, down-checking the Mini-SD card. You must reformat the card to clear all the data before it can be used.

If you hear the breakwire-launch error code, power the unit off before attaching the break wire.

This unit has had limited testing with hybrid motors at this time, and is not yet fully qualified. Please see our website at: <http://www.gwiz-partners.com>, where we will post further updates.

Table of Contents

- Introducing the G-Wiz HCX..... 1
 - Components 3
 - Product Features 4
- Flying your HCX Flight Computer..... 7
 - Setting up your Hardware 7
 - Mounting the Flight Computer in your Rocket 10
 - Getting Ready for Launch 12
 - Recovering your Rocket 13
 - Analyzing your Flight Data with the FlightView Program 14
 - Conclusion..... 17
- Using the G-Wiz Flight Computer for More Advanced Flights 18
 - Using FlightView to Change the Configuration of your HCX..... 18
 - Cookbook for Launch Setups 22
- Appendix A – Product Specifications..... 34
- Appendix B – Flight Computer Status Codes..... 35
 - Normal Status Code..... 35
 - Non-Fatal Error Status Codes..... 35
 - Fatal Error Status Codes 36
 - POST Failure Code Lookup Charts..... 37
- Appendix C – Mechanical Drawing..... 38
- Appendix D –Installing USB Drivers on Macintosh 39
- Appendix F – Installing USB Drivers on Windows XP 40
- Appendix F – Installing USB Drivers on Windows Vista 42

List of Procedures

- To Set Up the On-Board Hardware..... 8
- To Wire Up Your Power Connection 8
- To Test the Setup 9
- If You Do Not Hear the Correct Sequence 9
- If You Hear the Correct Sequence, Your Setup is Complete..... 9
- To Prepare Your Flight Computer for Launch..... 12
- To Read the Data from your Mini-SD Card 14
- To Save the Flight Data to your Personal Computer 16
- To Connect your Flight Computer to your Personal Computer 20
- To Change your Configuration 20
- To Correct the Setup, If You Want a Breakwire Flight 36
- To Correct the Setup, If the Breakwire Mode was Configured by Mistake..... 36
- To Install the USB Drivers on a Macintosh..... 39

List of Setups

- Dual Parachute Deployment Using One Nine Volt Battery..... 24
- Dual Parachute Deployment using Two Batteries 26
- Two Stages plus Dual Parachute Deployment using Two Batteries..... 28
- Single Parachute Deployment at Apogee with a Single Nine Volt Battery 30
- Cluster Ignition, Single Parachute Deployment at Apogee Using Two Batteries 32

Introducing the G-Wiz HCX

Congratulations on purchasing your new G-Wiz HCX Flight Computer! The G-Wiz HCX is a very robust, safe and reliable unit that will support a wide variety of rocketry needs. If this is your first altimeter-based flight computer, you can rest assured that the G-Wiz HCX will grow with you.

The G-Wiz HCX is more than just an altimeter. If you're familiar with altimeters and have experience flying rockets with electronics, you'll be excited at the flexibility that the HCX offers, no matter what type of rocket you're flying.

You can configure HCX for many different types of flight plans. Using FlightView, our flight computer communication and data analysis software, you can fly many different setups on your HCX. For example you can:

- Fly a single stage rocket and deploy a chute at apogee.
- Fly a single stage rocket where you deploy a drogue at apogee, and then deploy your main at a preset altitude of your choosing.
- Initiate air start of clustered motors within one second after the rocket has cleared the launch pad.
- Fly multi stage rockets where you choose how long after the booster motor burns out before you ignite the sustainer motor.
- Fly extreme altitude flights, where the HCX can measure barometric altitude as high as 100,000 feet above sea level (ASL).
- Fly very-high-G short-burn-time motors, when you configure the G-Wiz HCX Flight Computer to use a break wire for launch detection.
- Record user-provided sensor data during flight when you use the BreakWire/Analog input port to feed sensor data into your flight computer.
- Fly the HCX as a redundant backup flight computer in any flight. Since all of the output events can be configured to fire at a delay of your choosing, you can use a second G-Wiz flight computer as a redundant backup. Because HCX fires all the events independently, it can be useful on those mission critical flights, such as a High Power certification flight.

You can also combine these setups to fly an extremely intricate flight plan.

What makes the G-Wiz HCX Flight computer so much more than just an altimeter? The HCX has dual sensors – an accelerometer as well as a barometer – which continually feed data to the RISC processor at the heart of this third-generation flight computer. Using this data and the onboard programming, the flight computer determines the key events in a rocket's trajectory, including:

- Launch.
- Booster burn-out.
- Sustainer ignition.
- Sustainer burn-out.
- Inertial apogee.
- Barometric apogee.
- Deployment

- Landing.

HCX has four independent high-current output ports. Each one can independently control a flight event. This allows you create a flight plan with up to **four** separate flight operations. While the two parachute pyro ports are single tasked for recovery deployment, the third pyro port can be used for either sustainer ignition or for cluster ignition. The fourth pyro port is programmable in FlightView, our flight computer program, for a myriad of possible events. You can program four possible events into your flight plan including these options:

- Apogee deployment.
- Low altitude deployment.
- Very high, below apogee deployment.
- Air-start of a cluster of motors.
- Mid-air ignition of sustainer motors.
- Event activation based on data from a user-provided sensor.

In addition to the inputs from the accelerometer and barometer, the HCX can also record data from the analog input port. This port can be used for:

- Mechanical detection of launch using a break wire.
- Data recording from a user-provided analog sensor.

The standard model, the HCX/50 unit, can accurately measure up to 56G of positive or negative acceleration, while other models can accurately measure up to 224G.

The unique pyro port shunt plug in the HCX prevents the pyro ports from accidentally firing while you are working on, or transporting, your rocket.

The on-board beeper starts to read out the peak altitude upon landing. It continues until after you recover your rocket and you turn it off.

HCX keeps track of multiple flights by recording the accelerometer and barometric sensor data into a file on a Mini-SD memory card.

Our FlightView software, which runs on Windows, Mac OS X, and Linux platforms, reads the files from the Mini-SD card. This program analyzes your flight data, presents it in graphical format, and allows you to save the data to your personal computer.

Components

Here are the major components of the G-Wiz HCX flight computer. More information on each of these components is in the [Using your Flight Computer](#) chapter of the [HCX User Manual](#).

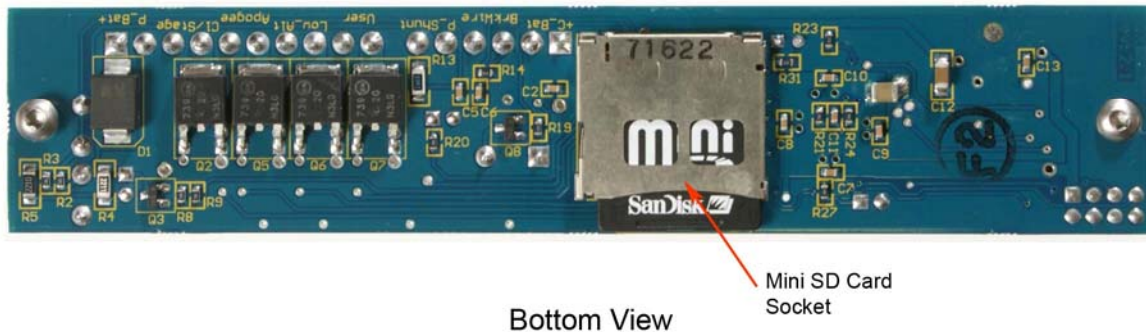
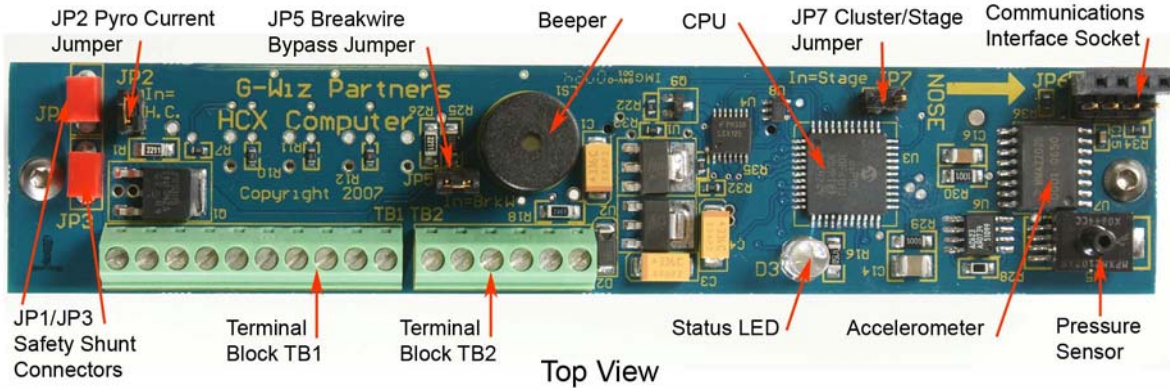

- **CPU** – The RISC processor that controls the Flight Computer.
- **Mini-SD Card Socket** – Insert a Mini-SD card to record your flight data.
- **Accelerometer** – Continually measures acceleration during the flight.
- **Pressure Sensor** – Continually measures barometric pressure to calculate altitude.
- **JP1 & JP3 Safety Shunt** – Always use the safety shunt when your flight computer is controlling pyrotechnic events.
- **JP2 Pyro Current Jumper** – Sets high or low current operation for the pyro ports.
- **JP7 Cluster/Stage Mode Jumper** – Defines when pyro port 1 is activated.
- **JP6 Communications Interface Socket** – Attach a G-Wiz Interface Card here when you want to connect to your personal computer.
- **JP5 Breakwire Bypass Jumper** – Sets electrical connections to utilize information from the Breakwire/Analog input.
- **Beeper** – Audibly indicates status.
- **Status LED** – Visually indicates status.
- **TB1 & TB2 Terminal Blocks** – Connect wires to the flight computer here.

Product Features

Here are some of the great features you'll find in your new G-Wiz HCX state-of-the-art flight computer. For more detailed information on using these features, please see the [G-Wiz HCX User Manual](#).

Robust Hardware

- Integrated barometer and accelerometer work together for very precise and accurate altitude detection.
- The barometric sensor is capable of accurate altitude sensing as high as 70,000 feet MSL.
- The 12-bit A to D converter, plus the third generation 8 MIPS RISC processor, provides reliable operation, flight after flight.
- Continuous CPU, pyro battery, and continuity monitoring prior to launch instantly alerts you if an electrical problem occurs in your rocket before flight.
- The HCX flight computer has three models. This chart shows the model numbers and the maximum acceleration each model can measure.

Model Number	Maximum Acceleration
HCX/50	+/- 56 G
HCX/100	+/- 112 G
HCX/200	+/- 224 G

Interactive Hardware Features

- Integrated speaker and bright blue LED, that is visible in bright daylight conditions, indicate configuration and operational status before the flight.
- The beeper and LED read out peak altitude after landing. You can configure the unit to beep out the maximum airspeed too.

Configuring your Flight Computer

Interface cards are available in either RS-232 or USB formats. These cards attach to the 8 pin communications interface socket (JP6) and allow you to connect with a personal computer. Once connected with your personal computer you can use the FlightView software to:

- Upload configurations to your flight computer.
- Bench test electric matches and other accessories,
- Upgrade your flight computer's firmware.

The FlightView program allows you to change the configuration of your flight computer to match your flight plan.

- You can configure the beeper to read out in either Metric or English units.
- You can configure pyro channel 1 for staging, and program it to operate a 1st, 2nd, or 3rd stage event.
- You can configure pyro channel 1 to ignite a cluster of motors immediately after launch.

- You can configure pyro channel 2 to fire at either barometric or inertial apogee.
- You can configure pyro channel 3 to activate the low-altitude event at either a set altitude or a specified time after inertial apogee.
- You can configure the flight computer to record in either Metric or English units.
- You can configure pyro channel 4 to:
 - Activate an event based on data from a 3.3v or 5.0v user-provided sensor.
 - Activate an additional event based on data from the barometer or accelerometer.
 - Turn off the same or a different event.
- You can choose to delay activating any channel's event. The delays can be set in 0.1 second increments with the range of 0 to 25 seconds.
- You can set the recording rate to 66.67 samples per second to 500 samples per second in 6 user selectable settings. Recording bit depth is 12-bits per sample.

Data Storage

- The firmware is stored in flash memory, and can be conveniently upgraded by the user when new versions are released by G-Wiz Partners.
- The flight computer's configuration is stored in non-volatile EEPROM.
- The flight computer records its data on a removable Mini-SD memory card.
- The flight computer records acceleration, pressure, and events during the flight.
- The Mini-SD card can record multiple flights between downloads without risk of data loss.
- The included SD card adapter allows convenient download of flight data to your personal computer
- Flight data is analyzed using FlightView software
- Flight data can be stored on a personal computer in **gwiz** format, for review using FlightView, or in **txt**, **csv**, or **xml** formats for use in other analyses.

FlightView Software

- Available for Windows, Macintosh, and Linux systems.
- Use it to:
 - Download flight data recorded during the flight from the Mini-SD memory card.
 - Analyze and chart the recorded and calculated data from your flight
 - Save the flight data to your personal computer.
 - Configure your HCX flight computer.
 - Bench test your HCX flight computer.

Power

- In low current mode, a single battery powers both the flight computer's CPU and the pyro ports.
- In high current mode, two batteries can provide up to 8 amps of continuous current to each pyro port, to reliably fire igniters and/or electric matches.

Safety

- An on-board safety shunt prevents arming of HCX pyro ports while you are transporting or working on your rocket. It is designed to be quickly and easily removed once the rocket is on the pad and ready for launch
- The on-board safety shunt is wired in parallel with the terminals of an optional external shunt. This allows you to place the pyro safety switch at whatever location is most convenient for the configuration of your rocket.
- High current, open drain, power MOSFET switches safely initiate the pyrotechnic events.
- A reverse-protection diode protects your flight computer from the damage that could be caused by accidentally connecting a battery backwards.
- The firmware prevents pyro port 1 from firing a sustainer motor if the rocket has already passed apogee.
- If you have configured your flight computer for breakwire detection, the firmware checks the port's continuity at power-on and sounds an alert if the break wire's circuit is open.

Flying your HCX Flight Computer

The best way to get to know your G-Wiz HCX flight computer is to start using it. This tutorial walkthrough is based on using it in its simplest mode: as an altimeter in the default G-Wiz configuration. This setup is based on using a single battery and not firing any events. The computer will log all of the flight information on the Mini-SD card.

Your Flight Computer and Accessories

Your flight computer comes in a pink antistatic zipper bag and also has these accessories:

- Safety Shunt plug
- Mini-SD Card and Adapter
- Two 9v battery adapters
- Information sheet
- Three small black jumpers attached to their pins

Retain the antistatic bag to store your flight computer between uses.

Two nine volt battery adapters are included for your use. If you misplace or damage either of the adapters, please make sure to purchase high quality, well constructed battery adapters. Cheaply made adapters can lose contact under the stresses of flight computer acceleration, potentially causing catastrophic failure.

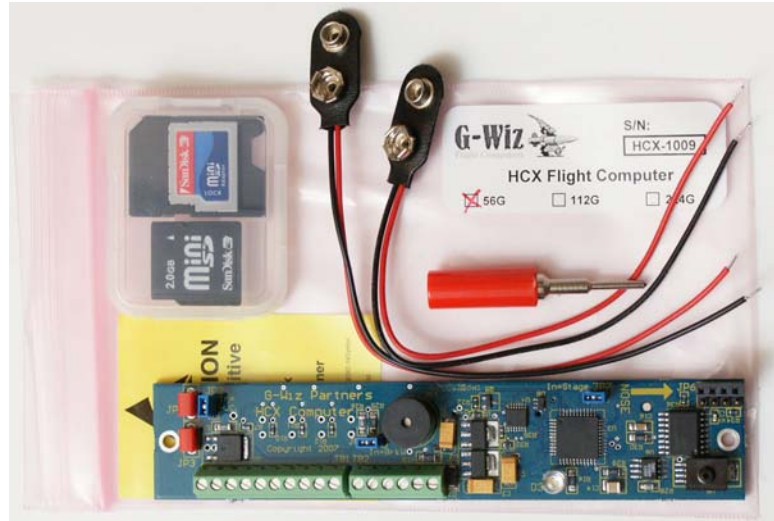

Setting up your Hardware

The terminal blocks are used to connect all the wires to the flight computer. Terminal block 1 is grouped into five pairs of pins which are all part of the pyro system. Terminal block 2 has three pairs of pins including the power connection to the CPU and two different input ports. Each pair of pins has a specific function. Input functions include battery power and data inputs. The outputs connect the flight computer to your pyro devices.



This illustration is a map to the pin assignments on the terminal blocks. This view is the same as looking down on the top side of the flight computer with its “nose” end pointing to your right. The terminals are the holes in the side of each pin position where you insert your connecting wires.

TB1 - Pyro Port Pin Assignments										TB2 - Power / Special					
Pin 1	Pin 2	Pin 3	Pin 4	Pin 5	Pin 6	Pin 7	Pin 8	Pin 9	Pin 10	Pin 1	Pin 2	Pin 3	Pin 4	Pin 5	Pin 6
P Batt+	P Batt-	Pyro 1	Pyro 1	Pyro 2	Pyro 2	Pyro 3	Pyro 3	Pyro 4	Pyro 4	Shunt	Shunt	Input	Input	C Batt-	C Batt+
Pyro Battery		Cluster / Stage		Apogee		Low Altitude		Programmable		Pyro Shunt		B Wlre / Analog		CPU Battery	

Note: Make sure you loosen the attachment screws before trying to insert wires into the terminal, and then tighten them down again to get a good electrical connection.

To Set Up the On-Board Hardware

1. Prepare your rocket for flight using a motor-based ejection system
2. Insert a FAT or FAT32-formatted Mini-SD card into the socket on the bottom side of the flight computer.
 - o For more information on formatting your Mini-SD card see [Formatting Mini-SD cards for use in your G-Wiz HCX](#) in the [Using your Flight Computer](#) section of the [User Manual](#).
3. Remove the **JP2** jumper.
 - o These pictures show where the JP2 jumper is being removed.
 - o Make sure you store the jumper in a safe place until you need it again.

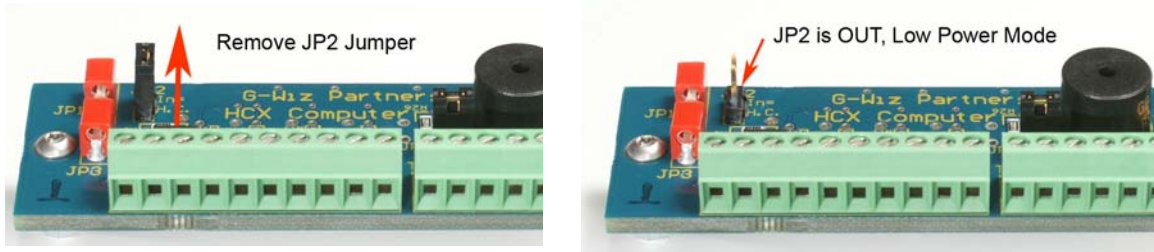

To Wire Up Your Power Connection

1. Run a wire from the positive CPU battery terminal (TB2 pin6), marked **CBatt+** to the positive pyro battery (**PBatt+**) terminal (TB1 pin1), as shown on the pyro port pin assignment charts.
2. Using the provided nine volt battery connector, attach the positive (red) battery wire to the positive CPU battery terminal (**CBatt+**, TB2 pin6).
3. Attach the negative (black) battery wire to the negative CPU battery terminal (**CBatt-** TB2 pin5).
4. Use a screwdriver to tighten the screws and get a good contact on the wires.
5. Tug gently on each wire to make sure it has a good connection.

Your flight computer should now look like this:

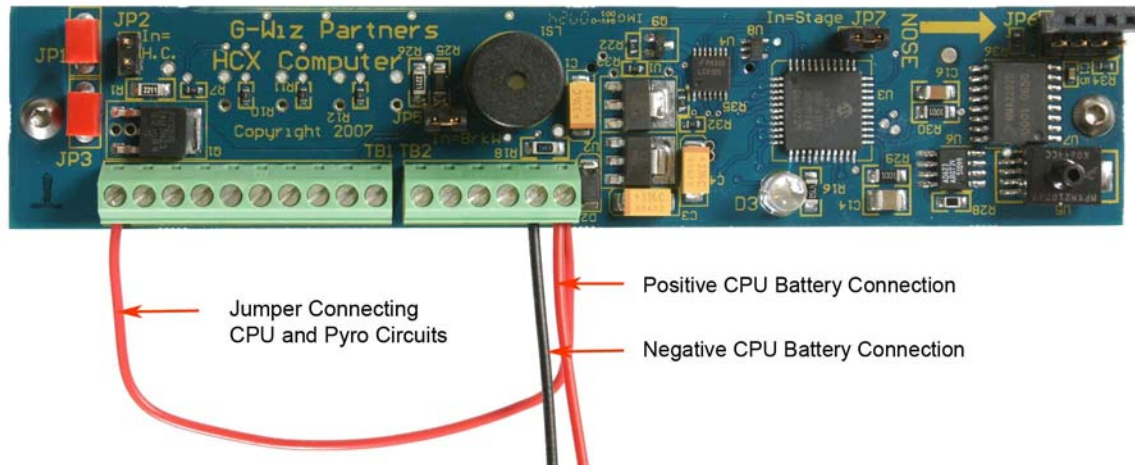

To Test the Setup

Power your flight computer on. Watch the LED and listen to the Flight Computer Status beep code. The correct sequence is:

1. LED turns on then off.
2. The LED turns on and the beeper gives one (JP7 OUT) or two (JP7 IN) low pitch beeps.
3. LED turns off.
4. There is a half second pause.
5. Starting with pyro port one, each pyro port reports status with either a single quick “beep” if the port has good continuity or a double “beep” if the port has no continuity.
6. There will be a one second pause, and then the sequence will repeat from step b.

If You Do Not Hear the Correct Sequence

1. Note the exact status code readout.
2. Refer to the status codes lists in Appendix B.
3. Power the flight computer off.
4. Make your changes to correct the problem.
 - o Is your SD Card installed correctly?
 - o Are all your jumpers enabled correctly?
 - o Are your wires correctly inserted in the terminals?
5. Power your computer on again and listen to the flight computer status beep code.

If You Hear the Correct Sequence, Your Setup is Complete

1. Power the unit off.
2. Mount the flight computer in your rocket.

Mounting the Flight Computer in your Rocket

Rigidly Attach the G-Wiz HCX Flight Computer to your Rocket.

You must install your flight computer so that it is rigidly attached to your rocket. If the flight computer is allowed to move freely around in a payload bay, it will not accurately record the flight and will report significant errors in the recorded flight data. In addition, the impact of the unit against the inside walls of your rocket could damage the flight computer's components.

As shown in this picture, the flight computer is designed to be mounted with two 4-40 thread machine screws. Appendix C has a drawing of the board showing the locations and dimensions of the mounting holes and other important features.



Securely Anchor the Batteries

Ensure that all batteries used to power the flight computer are securely mounted and anchored inside the rocket. The typical G forces involved in even a model rocket flight will cause an unsecured battery to whip around in the payload bay. Not only could it smash into the flight computer's electronics, but if the battery leads are pulled out, you will lose all power to the flight computer. If this happens, your HCX will stop recording and it will be unable to fire any pyrotechnic events, including the parachutes.

Mount the Flight Computer in the Correct Orientation

The flight computer must be mounted in the correct orientation to operate. **It will NOT operate correctly if it is installed upside down.** The computer must be mounted along the axis of the rocket with the nose end of the flight computer forward. As seen in this photograph, the nose end of the flight computer is indicated on the board with a printed arrow. Also, the terminal blocks are at the rear, or aft end of the flight computer.

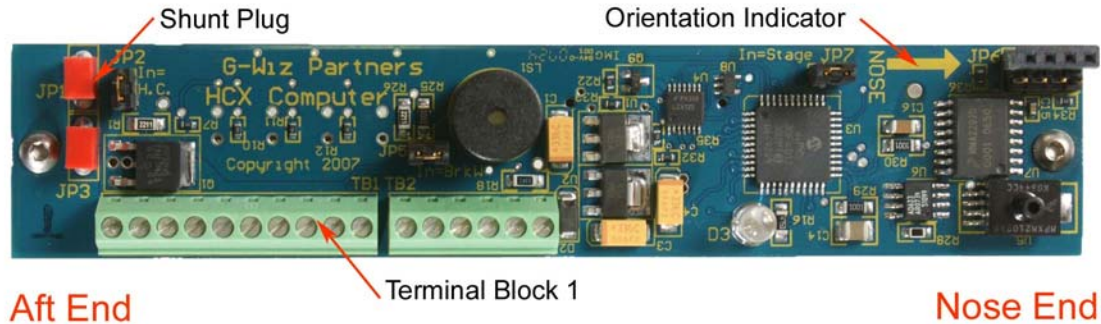

This photograph shows a top and bottom view of the G-Wiz HCX installed in a Nova Payloader rocket. Please note that the shunt plug is nearer to the aft end of the rocket.

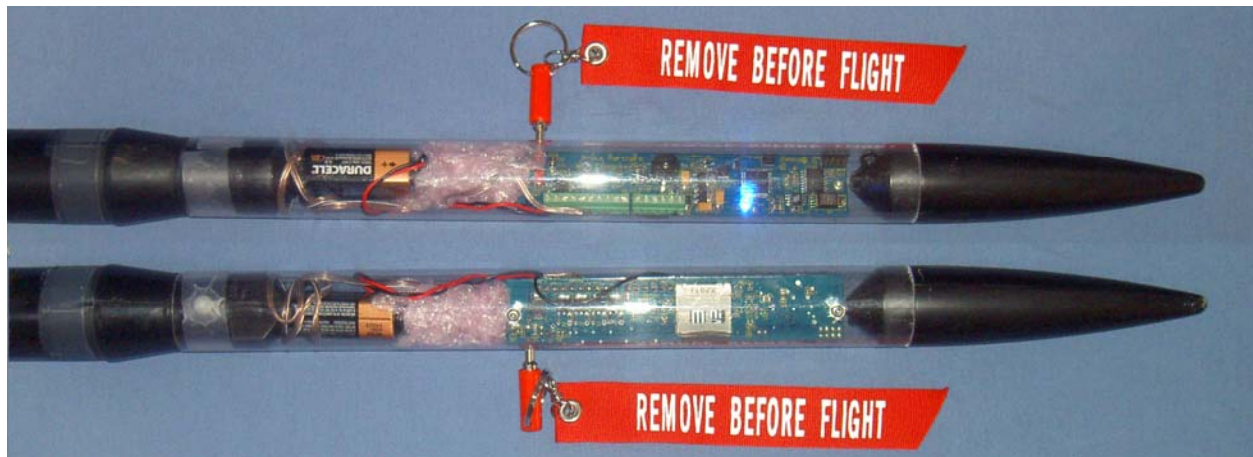

Provide Atmospheric Access for the Flight Computer

You will need to drill a hole in the payload bay to equalize the pressure inside and outside of the rocket. Otherwise the pressure sensor will be unable to detect altitude due to atmospheric pressure changes. . One 1/8 inch hole at least 6 inches below the nose cone will be sufficient for a rocket of 1 to 2 inches in diameter. In this picture, the hole drilled for the shunt plug access is the only air access needed.

Protect the Flight Computer from Ejection Gasses

Ejection gasses are corrosive and will damage the flight computer. Damage from ejection gasses will void your warranty. Ensure that any methods used to mount the computer and run wiring to your pyro charges prevents ejection gasses from coming in contact with the flight computer.

Getting Ready for Launch

Once your flight computer is set up and the rocket is prepared, then you need to put them both together. Because we are not using the HCX flight computer to control ejection on this flight, make sure to include motor ejection on your flight plan.

To Prepare Your Flight Computer for Launch

1. Turn on power to the flight computer.
2. Listen to the flight computer status beep codes.
 - If they are incorrect:
 - a. Shut down the HCX,
 - b. Recheck your setup.
 - c. Power it back up to check them again.
 - A full list of the flight computer status codes is available in [Appendix B](#).
 - If they are correct, mount the flight computer in your rocket.
3. Finish prepping your rocket, including your motor-based ejection.
4. At the pad, turn on your computer if it is not already on.
5. Listen to the flight computer status beep codes.
6. If everything is OK, finish connecting your rocket for launch.
7. Watch your rocket fly!

Recovering your Rocket

As soon as your flight computer detects landing, it will start to read out its maximum altitude. The numbers are beeped out in quick sequences with very brief pauses between each number sequence. Zero is a long beep.

- Zero is represented as a long beeeep,
- One is a single quick beep.
- Two is a pair of quick beeps.
- .
- .
- .
- Nine is 9 quick beeps.

After the complete altitude number is read out, the unit will pause for ONE FULL SECOND and then repeat the number sequences until you power off the unit.

This chart shows some examples.

Altitude (feet)	Beep Code
5,081	Beep, beep, beep, beep, beep (5) – long beep (0) – beep, beep, beep, beep, beep, beep, beep, beep (8) – beep (1)
12,112	Beep (1) – beep, beep (2) – beep (1) – beep (1) – beep, beep (1)
9,817	Beep, beep, beep, beep, beep, beep, beep, beep, beep (9) – beep, beep, beep, beep, beep, beep, beep, beep (8) – beep (1) – beep, beep, beep, beep, beep, beep, beep (9)

The computer must be turned off and then on to reset it before you can launch again.. All your flight data is safely stored on the Mini-SD card.

If you want to do another flight, prep the rocket and then power up the flight computer when you get to the pad. Each flight is saved under a sequential file number.

Analyzing your Flight Data with the FlightView Program

When you have completed your flight, remove the Mini-SD card and connect it to your personal computer. You can insert it into:

- The provided Mini-SD to SD adapter and then into an SD Card reader attached to your personal computer.
- A Mini-SD Card reader attached to your personal computer.

Use the FlightView program to read detailed information from your flight(s). If you need to install FlightView, you can download it from the G-Wiz web site, <http://www.gwiz-partners.com/Downloads/install/install.html>.

To Read the Data from your Mini-SD Card

1. Make sure the G-Wiz Flight Viewer program, FlightView, is installed on your computer.
2. Put the Mini-SD card into its SD card adapter.
3. Plug the card into an SD reader attached to your computer.
4. Open the FlightView program.

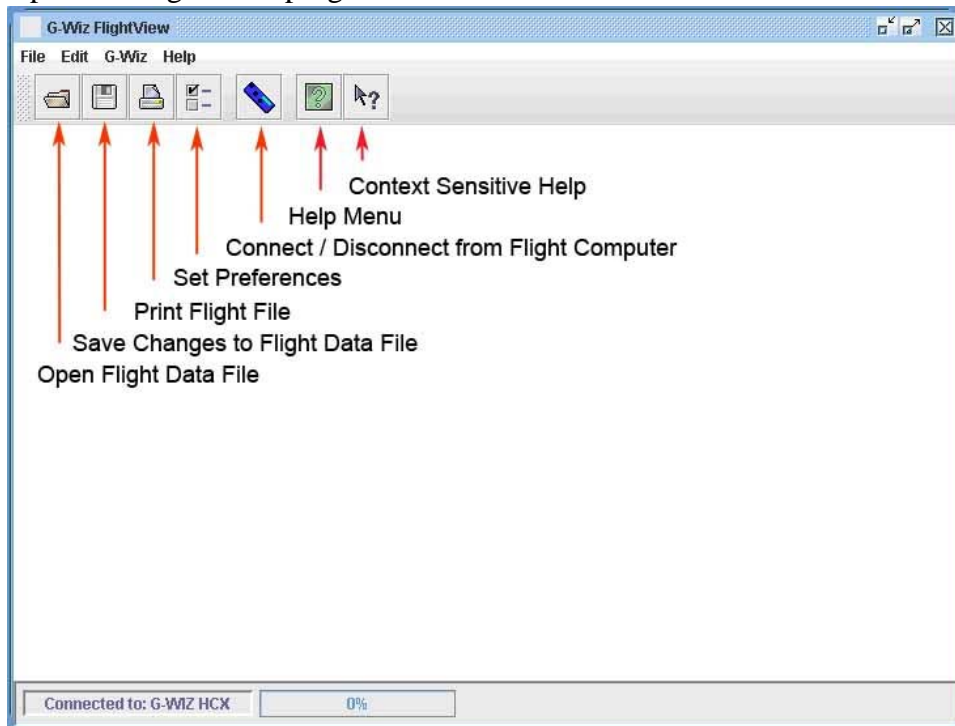

5. On the toolbar, click on the **Open Flight Data File** button, or select **File > Open** from the menu bar.
6. Using the **Open** dialog box, navigate to your Mini-SD card's directory.
 - Your flight files will be listed in sequential order. For example:

```

FLT0000.GWZ
FLT0001.GWZ

```
 - Every time you turn on your flight computer, it creates a file in preparation for flight. Therefore you probably will have one more flight file on your Mini-SC card than you

flew. Unless you have powered your flight computer on since flying it, the highest number contains your file.

7. Select the file name and click the **Open** button to open the flight file.
8. Click the **Flight Information** tab if you want to add detailed information on the rocket and motor you used for the flight.

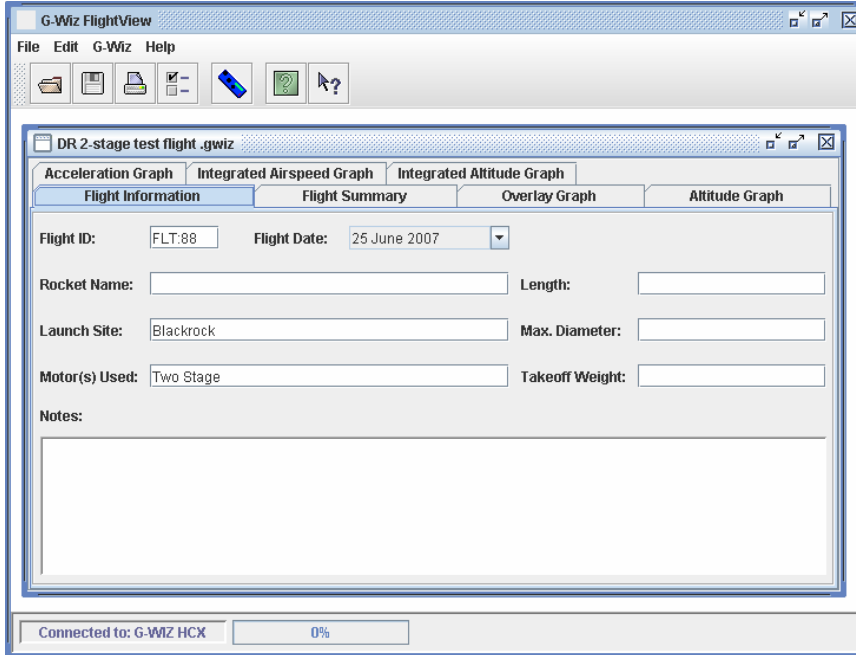

9. Click the Flight Summary tab for an overview of all the parameters measured during your flight.

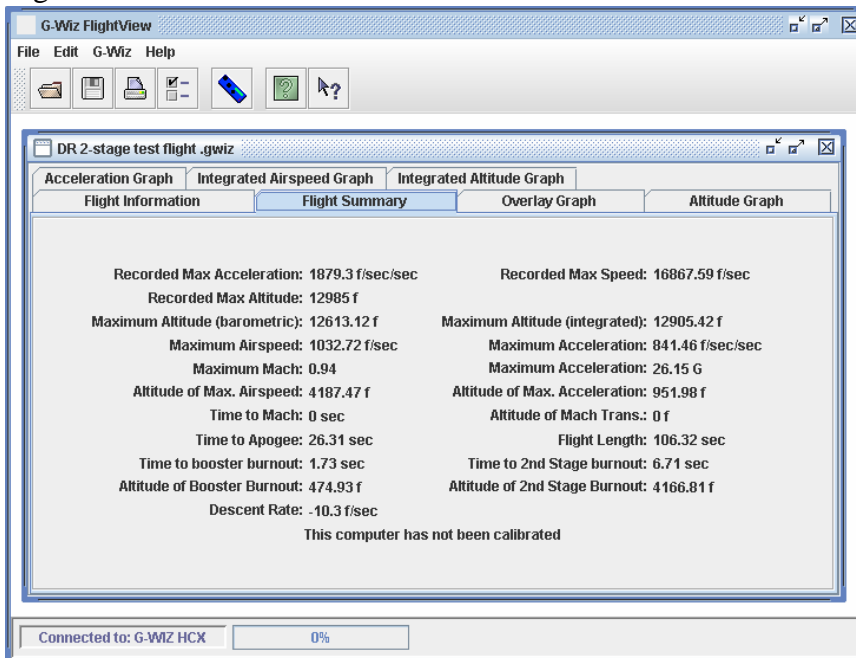

10. Click the **Overlay Graph** tab to see a graph of the measured and calculated data on the same time axis.

- o You can change what data appears in the overlay graph by making selections in the **Preferences** window.
11. Click the other tabs to see graphs of the measured and calculated data in graphical form.

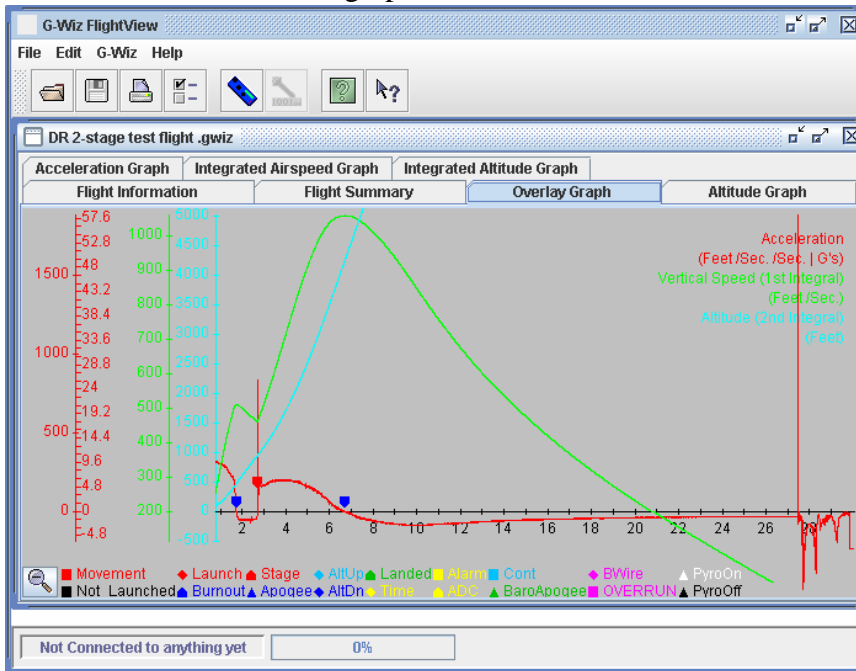

To Save the Flight Data to your Personal Computer

1. Click the **Save Document as** button on the FlightView main menu bar or select **G-Wiz > Save As** from the main menu.
2. Navigate to the directory where you plan to store your flight data.

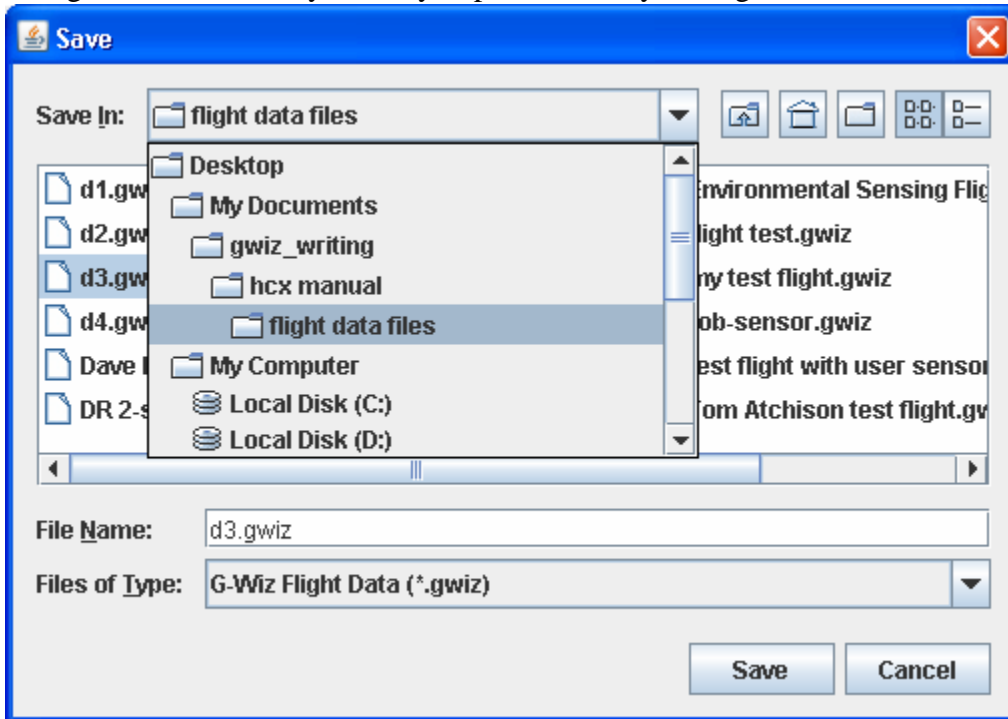

3. In the drop-down **Files of Type** box, select **gwiz** to save your data in a format readable by FlightView.
 - o For information on other save formats available, see the **Using FlightView Software** chapter of the **G-Wiz HCX User Manual**.
4. Type in a save name for the file and click **Save**.

Caution: Make sure you save your flight file to a directory on your personal computer and do not re-save it back on the Mini-SD memory card.

You can continue saving flights to the same SD card until it is full. To delete the files on the card, format the SD card with FAT or FAT32 file system on your personal computer.

For more information on all of the features available in FlightView, see the **Using FlightView Software** chapter of the **G-Wiz HCX User Manual**.

Conclusion

Now that you have experienced the G-Wiz HCX flight computer in action, we strongly recommend that you read the **G-Wiz HCX User Manual**. It is available for download at the G-Wiz web site, <http://www.gwiz-partners.com/Downloads/html/docs.html>.

In that manual you will find detailed information on using the advanced features of the G-Wiz HCX flight computer. This includes detailed information and troubleshooting information for connecting your flight computer directly to your laptop computer. It also includes detailed information on the hardware features of this flight computer.

Using the G-Wiz Flight Computer for More Advanced Flights

Many people want to start using all of the advanced features of this flight computer right away. We strongly recommend that you download and read the [G-Wiz HCX User Manual](http://www.gwiz-partners.com/Downloads/html/docs.html) from the G-Wiz web site at <http://www.gwiz-partners.com/Downloads/html/docs.html> before you plan your next flight.

But, we know Rocketeers. This next section briefly describes the steps to set up the G-Wiz HCX for more complex flight plans. Where you might have any problems, we have tried to point you to the right section of the [User Manual](#) to find your answer.

Using the Safety Shunt

Unless you are using motor ejection, we recommend that you **always** include a pyro shunt in your flight computer setup. When it is properly installed, connecting JP1 and JP3, it protects the pyro ports from accidentally firing during setup or transport.

You should use the built-in shunt (JP 1/3) any time the HCX is mounted in the rocket in a position where the shunt plug can be inserted through a hole in the airframe.

In normal use, insert the shunt before you power the unit on, and remove it, on the pad, only after all other prep work is completed.

Once you remove the shunt, the flight computer will arm the pyro outputs, enabling them to fire when they are signaled by the configured program.

This picture shows the safety shunt correctly installed into the JP1/JP3 shunt connectors

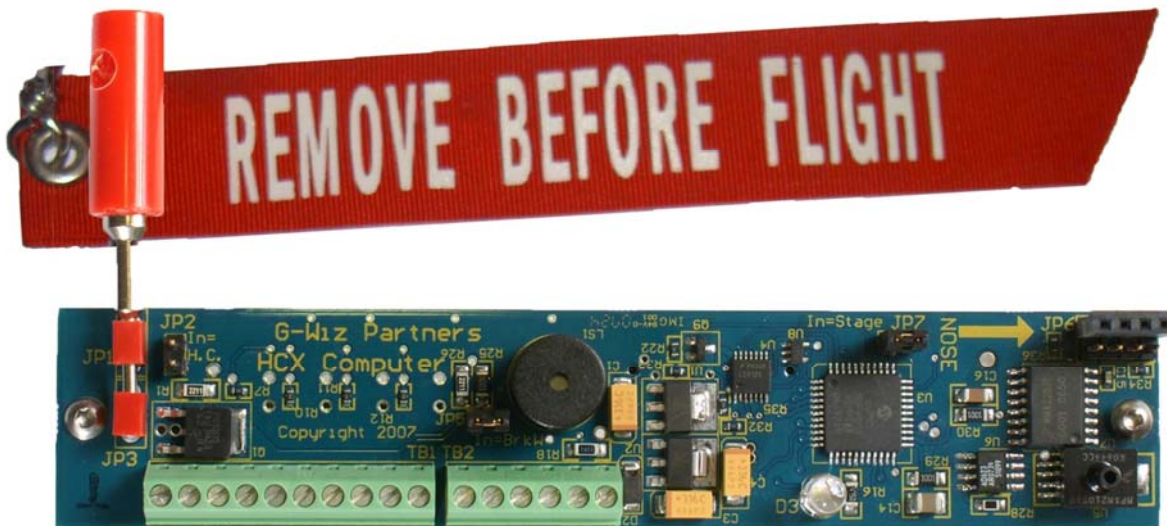

The HCX has an additional parallel safety shunt input at pins 1 and 2 on terminal block 2. If either circuit is closed, the pyro ports will not fire. You can use this shunt connection if your application does not allow you to easily install and remove the plug from the built in shunt. See the “[The External Safety Shunt](#)” section of the [G-Wiz HCX User Manual](#), for more information.

Using FlightView to Change the Configuration of your HCX

More advanced flight computer setups will often include changes to your configuration memory. The factory default configuration settings for the G-Wiz HCX flight computer are:

- Staging is for first stage.
- Low altitude deployment is set for 800 feet.
- English units are used.
- No delays are put into any of the events.

If these settings work for your flight plan, then you do not need to configure your flight computer.

The Communication Interface Card

In order to change your configuration you first need to connect your flight computer to your personal computer. You will need a G-Wiz Communication Interface card. These cards fit onto the 8 pin Communication Interface socket (JP6) at the nose end of your HCX flight computer. The interface card is available from your retailer in either USB or RS232 formats. If you have used other G-Wiz flight computers, it is the same interface card used for the LCX and MC2 flight computers.

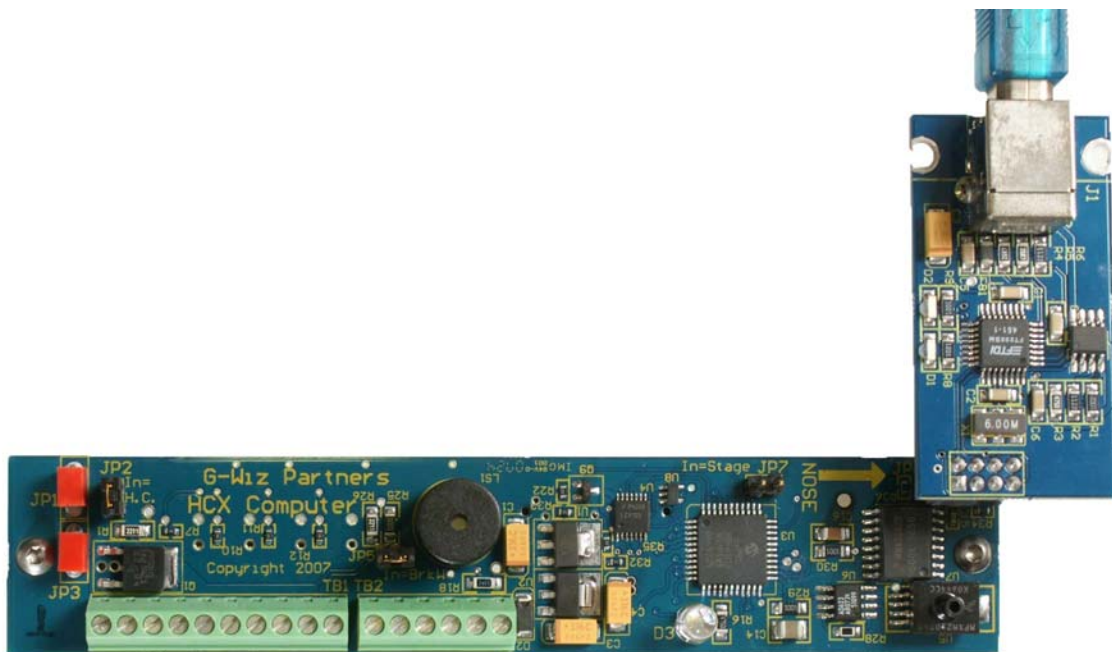

Using the Interface Card

For more detailed information on the connection and configuration processes, including screenshots, see the [Using FlightView Software](#) chapter in the [HCX User Manual](#).

To Connect your Flight Computer to your Personal Computer

1. Make sure that FlightView is installed on your computer.
2. Wire your flight computer for single battery operation without any events.
 - Refer to the [Setting up your Hardware](#) section for detailed instructions.
3. Connect your G-Wiz Interface Card and its data cable to your personal computer.
 - If you are using the G-Wiz USB interface, your personal computer will start to install the drivers as soon as you connect the card to your computer.
 - ◆ If you have a Macintosh or Windows XP or Vista computer, and have any problems with the USB driver installation, refer to the [Appendix](#) where you will find step by step instructions for installing the drivers.
 - The G-Wiz serial interface does not require any drivers to be installed.
4. After the drivers have finished installing, start FlightView.
5. Go into the **Preferences** menu.
6. Click the **G-Wiz Connection Port** drop-down box and select the highest number **COM** port.
 - This will usually be the most recently installed port. If you know your flight computer interface is on a different port, select it instead.
7. Click **OK** to set the preferences and exit.
8. Connect your interface card to the eight pin connector
9. Power up the HCX unit.
 - It will start beeping the flight computer status.
10. Select **G-Wiz > Connect** from the main menu.
 - When it connects, the flight computer the flight computer will stop beeping and the box in the bottom left corner of the window will say: **Connected to: G-Wiz HCX**.
 - If the unit does not connect, check **Preferences** to see if the correct port is selected.
 - If you have any additional problems connecting, refer to the Using FlightView Software chapter in the User Manual.

To Change your Configuration

1. Select **G-Wiz > Configure**.
 - This dialog box will appear, allowing you to change the configuration memory to match your flight plan.

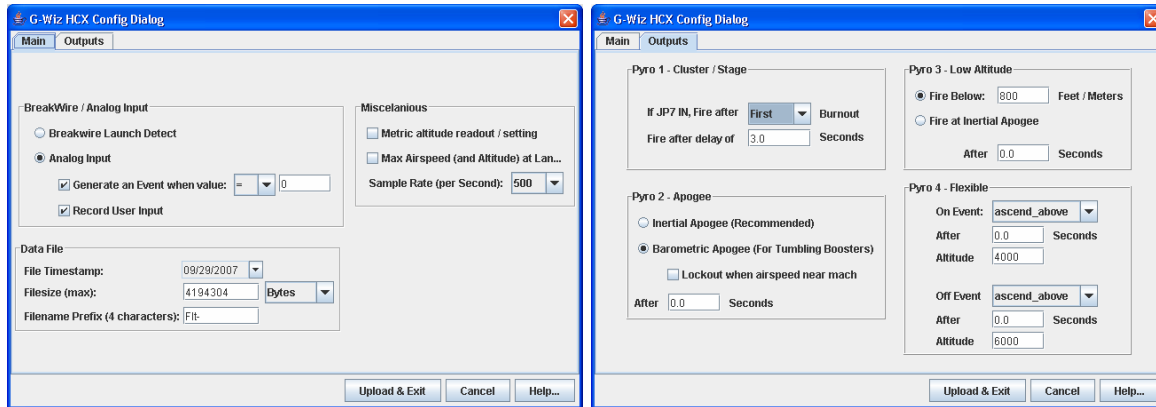

2. Change the configuration on both the **Main** and the **Outputs** tabs to match your flight plan.
3. Press **Upload & Exit** when you are done.
4. Disconnect the flight computer from FlightView.
5. Power your flight computer off.

The new configuration will be loaded when the flight computer is powered on again.

You can find more detailed information in the [Using FlightView](#) chapter in the [User Manual](#).

Cookbook for Launch Setups

This section contains step-by-step instructions for five commonly flown flight plans.

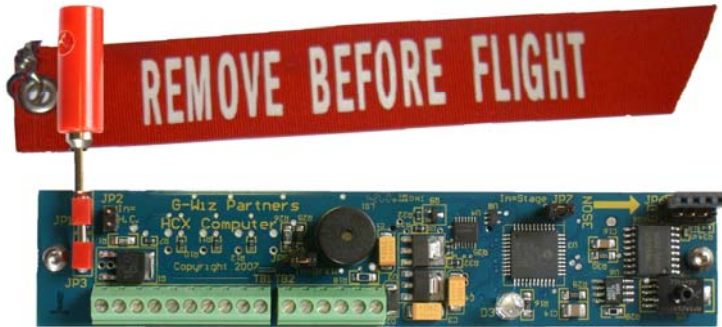

Important: All of these setups use a shunt plug to safe the pyro ports during setup and transportation. If your application does not allow you to use the shunt plug or the external shunt, you must test the unit by powering it on. Then you **MUST** shut it off until you have completed all the other launch preparations on the pad.

Tip: It may be more convenient for you to configure your flight computer before you set it up for flight. When you connect to your personal computer, you only need to set up the HCX for single battery operation. Also, your jumper settings are not important during the configuration process; you do not need to set them until you set up your unit for flight .

Note: When you fire the pyro ports in low current (single battery) mode, you must use an electric match with a low firing current. You can test your electric matches using the **Bench Test** program in FlightView. Detailed instructions are available in the [Bench Testing your HCX](#) section of the [User Manual](#).

When you design your flight computer's payload bay, you should build in a method to easily switch the flight computer's power on and off.

Jumper and Terminal Blocks Pin Assignments

Use these charts as guides for wiring batteries, ejection charges, and igniters

TB1 - Pyro Port Pin Assignments										TB2 - Power / Special					
Pin 1	Pin 2	Pin 3	Pin 4	Pin 5	Pin 6	Pin 7	Pin 8	Pin 9	Pin 10	Pin 1	Pin 2	Pin 3	Pin 4	Pin 5	Pin 6
P Batt+	P Batt-	Pyro 1	Pyro 1	Pyro 2	Pyro 2	Pyro 3	Pyro 3	Pyro 4	Pyro 4	Shunt	Shunt	Input	Input	C Batt-	C Batt+
Pyro Battery		Cluster / Stage		Apogee		Low Altitude		Programmable		Pyro Shunt		B Wire / Analog		CPU Battery	

Jumper Modes

Jumper Position Number	With Jumper IN	With Jumper OUT
JP 2 -- Pyro current selection	System allows High Current – two batteries must be used	System limited to low current – one battery can be used
JP 7 -- Cluster or stage selection	Stage mode enabled	Cluster mode enabled
JP 5 -- Breakwire Bypass	Breakwire launch detection enabled	User analog input (0-5v) enabled

Dual Parachute Deployment Using One Nine Volt Battery

This setup has no clustering or staging - A single battery powers both the computer and firing devices.

To Set Up the On-Board Hardware

1. Install a shunt plug into the safety shunt JP1/3.
2. Install your SD card in its socket.
3. Pull the jumper **OUT** of the JP2 twin pins.
 - o The JP2 is located near the fin end of the flight computer, next to the safety shunt. This picture shows the black jumper connector you remove from the JP2 jumper pins.
4. Put all the other jumpers **IN**.

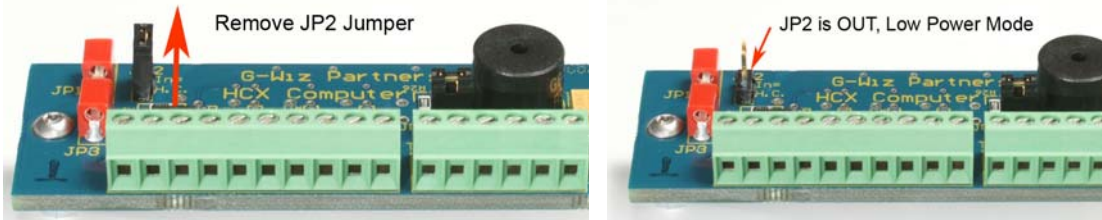

Your flight computer is now enabled for low pyro current. You must pull the jumper **OUT** and use low current, if you are using a single battery.

To Wire the Pyro Ports

1. Wire the drogue chute firing device to the two **Apogee** terminals (TB1 pins 5/6).
 - o Most electric match firing devices are not polarity sensitive.
2. Wire the main chute firing device to the two **LowAltitude** terminals (TB1 pins 7/8).

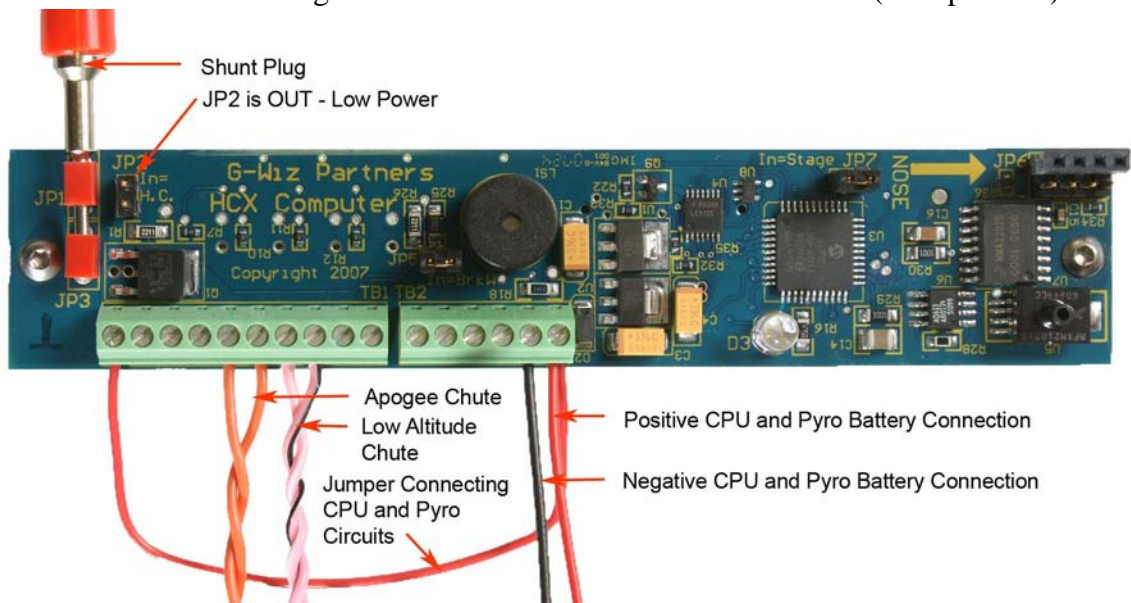

To Wire Up Your Power Connection

1. Run a wire from the **CBatt+** terminal (TB2 pin6) to the **PBatt+** terminal (TB1 Pin1).

2. Connect the power source to the **CBatt** terminals (TB2 Pins 5/6) making sure the polarity is correct and that the shunt plug is in place

To Test the Setup

After all the devices are hooked up, you can test the system. Make sure the shunt plug is correctly installed and then power the HCX on. The beeper will:

1. *Emit two quick beeps. – The battery is OK and the Cluster/Stage jumper JP7 is enabled for stage mode.*
2. *Emit two beeps. – The Cluster/Stage terminals have nothing connected.*
3. *Emit one beep. - The Apogee firing device has continuity.*
4. *Emit one beep. – The Low Altitude firing device has continuity.*
5. *Emit two beeps. – Nothing is connected to the Programmable terminals.*
6. *Then it will pause and cycle the beep pattern again.*

If this is not what you hear, refer to [Appendix B](#) for a list of the Flight Computer Status codes.

To Configure your Flight Computer

1. Connect your flight computer to your personal computer.
 - o See the instructions for connecting the flight computer in the [Using FlightView Software](#) section of the [User Manual](#).
2. Go into the **Configuration** menu.
3. On the **Main** and **Output** tabs, change the configuration settings to match your flight plan.
 - o If you have any problems, consult the [Configuring your HCX](#) section in the [Using FlightView Software](#) chapter of the [User Manual](#).
4. Click **Upload and Exit**.
5. Disconnect your flight computer from your personal computer.
6. Power your flight computer off and then on to load the new configuration into memory.

Once you've tested your setup by listening to the beep sequence and observing the status LED, you can leave it on, or turn it off, until the rocket is mounted on the pad. The launch sensor is pretty robust and the shunt plug will not allow the charges to fire.

Important: Do not remove the red shunt plug from JP1/3 until the rocket is mounted on the pad and ready to launch or until you power it off.

Dual Parachute Deployment using Two Batteries

This setup has no clustering or staging. One battery powers the computer and the other powers the pyro ports.

To Set Up the On-Board Hardware

1. Install a shunt plug into the safety shunt JP1/3.
2. Install your SD card in its socket.
3. Make sure the JP2 jumper is **IN**. The JP2 is located near the fin end of the flight computer, next to the safety shunt. This picture shows the black jumper connector being installed on the JP2.

Your flight computer is now enabled up for high pyro current.



To Wire the Pyro Ports

1. Wire the drogue chute firing device to the **Apogee** terminals (TB1 pins 5/ 6) (Davyfire 28b firing devices are not polarity sensitive).
2. Wire the Main chute firing device to the **LowAltitude** terminals (TB1 pins 7/8).

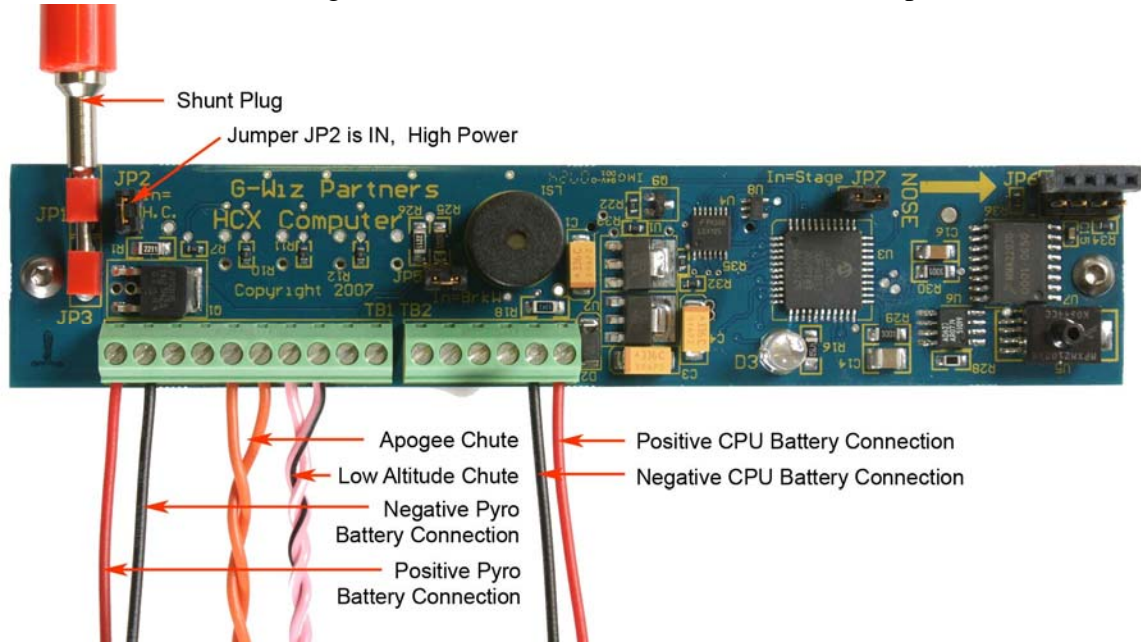

To Wire Up Your Power Connection

1. Wire a 9 volt battery for the computer to the **CBatt** terminals (TB2 pins 5/6) making sure your polarity is correct. You should have some method to switch the power to the computer on and off.

2. Wire a second battery, in the 9 to 15 volts range, for the pyro ports. Attach it to the **PBatt** terminals (TB1 pins 1/2) making sure your polarity is correct.

Important: DO NOT put a jumper wire from the positive computer battery terminal (CBatt+) (TB2 pin6) to the positive pyro battery terminal (PBatt+) (TB1 pin1).

To Test the Setup

After all the devices are hooked up, you can test the system. Make sure the shunt plug is correctly installed and then power the HCX on. The beeper will:

1. *Emit two quick beeps. – The battery is OK and the Cluster/Stage jumper JP7 is enabled for stage mode.*
2. *Emit two beeps. – Nothing is connected to the Cluster/Stage terminals.*
3. *Emit one beep. - The Apogee firing device has continuity.*
4. *Emit one beep. – The Low Altitude firing device has continuity.*
5. *Emit two beeps. – Nothing is connected to the Programmable terminals.*
6. *Then it will pause and cycle the beep pattern again.*

If this is not the pattern you hear, refer to Appendix B for a list of the Flight Computer Status codes.

To Configure your Flight Computer

1. Connect your flight computer to your personal computer.
 - o See the instructions for connecting the flight computer in the [Using FlightView Software](#) section of the [User Manual](#).
2. Go into the **Configuration** menu.
3. On the **Main** and **Output** tabs, change the configuration settings to match your flight plan.
 - o If you have any problems, consult the [Configuring your HCX](#) section in the [Using FlightView Software](#) chapter of the [User Manual](#).
4. Select **Upload and Exit**.
5. Disconnect your flight computer from your personal computer.
6. Power your flight computer off and then on to load the new configuration into memory.

Once you've tested your setup by listening to the beep sequence and observing the status LED, you can either leave it on or turn it off until the rocket is mounted on the pad. The launch sensor is pretty robust and the shunt plug will not allow the charges to fire.

Important: Do not remove the red shunt plug from JP1/3 until the rocket is mounted on the pad and ready to launch or until you power it off.

Two Stages plus Dual Parachute Deployment using Two Batteries

One battery powers the computer and the other one provides power for the pyro ports. The Cluster/Stage pyro port fires one or several motors after the booster burns out.

To Set Up the On-Board Hardware

1. Install a shunt plug into the safety shunt JP1/3.
2. Install your SD card in its socket.
3. Make sure the JP2 jumper is **IN**.
 - o The JP2 is located near the fin end of the flight computer, next to the safety shunt.
4. Put the JP7 jumper **IN** to enable the system for stage mode
 - o The JP7 jumper is located just forward of the status LED on the far side of the board.
- This photo shows both the JP2 and the JP7 jumper connectors being installed on their jumper pins.



Your flight computer is now enabled for high pyro current.

To Wire the Pyro Ports

1. Wire the drogue chute firing device to the Apogee terminals (TB1 pins 5/ 6)
2. Wire the main chute firing device to the LowAltitude terminals (TB1 pins 7/8).
3. Wire your staged-motor firing device to the Cluster/Stage terminals (TB1 pins 3/4)

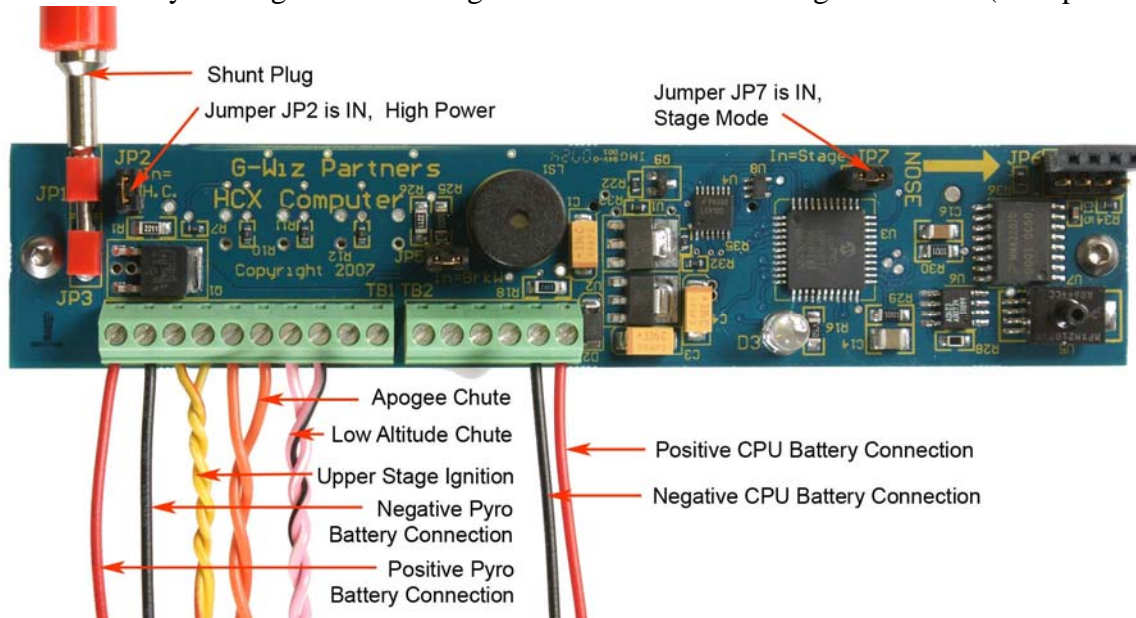

To Wire Up Your Power Connection

1. Wire a battery for the computer to the CBatt terminals (TB2 pins 5/6) making sure your polarity is correct
2. Wire a second battery, in the 9 to 15 volts range, for the pyro ports. Attach it to the PBatt terminals (TB1 pin 1/2) making sure your polarity is correct.

Important: DO NOT run a jumper wire from the CBatt+ positive computer battery terminal (TB2 pin6) to the PBatt+ positive pyro battery terminal (TB1 pin1).

To Test the Setup

After all the devices are hooked up, you can test the system. Make sure the shunt plug is correctly installed and then power the HCX on. The beeper will:

1. *Emit two quick beeps. – The battery is OK and the Cluster/Stage jumper JP7 is enabled for stage mode.*
2. *Emit one beep. – The Cluster/Stage firing device has continuity.*
3. *Emit one beep. - The Apogee firing device has continuity.*
4. *Emit one beep. – The Low Altitude firing device has continuity.*
5. *Emit two beeps. – Nothing is connected to the Programmable terminals.*
6. *Then it will pause and cycle the beep pattern again.*

If this is not the pattern you hear, refer to [Appendix B](#) for a list of the status codes.

To Configure your Flight Computer

1. Connect your flight computer to your personal computer.
 - o See the instructions for connecting the flight computer in the [Using FlightView Software](#) section of the [User Manual](#).
2. Go into the Configuration menu.
3. On the Main and Output tabs, change the configuration settings to match your flight plan.

If you have any problems, consult the Configuring your HCX section in the Using FlightView Software chapter of the User Manual.

4. Select Upload and Exit.
5. Disconnect your flight computer from your personal computer.
6. Power your flight computer off and then on to load the new configuration into memory.

Once you've tested your setup by listening to the beep sequence and observing the status LED, you can either leave it on or turn it off until the rocket is mounted on the pad. The launch sensor is pretty robust and the shunt plug will not allow the charges to fire.

Important: Do not remove the red shunt plug from JP1/3 until the rocket is mounted on the pad and ready to launch or until you power it off.

Single Parachute Deployment at Apogee with a Single Nine Volt Battery

This setup has no clustering or staging - A single battery powers both the computer and firing devices.

To Set Up the On-Board Hardware

1. Install a shunt plug into the safety shunt JP1/3.
2. Install your SD card in its socket.
3. Pull the JP2 jumper connector OUT.
 - o The JP2 is located near the fin end of the flight computer, next to the safety shunt. This picture shows the jumper connector being removed from the JP2 pins.



4. The other two jumpers must be IN.

Your flight computer is now enabled for low pyro current. You must set the jumper to low current if you are using a single battery.

To Wire the Pyro Ports

- Wire the main chute firing device to the Apogee terminals (TB1 pins 5/6).

To Wire Up Your Power Connection

1. Connect the power source, to the CBatt terminals (TB2 Pins 5/6) making sure the polarity is correct and that the shunt plug is in place.
2. Run a jumper wire from the CBatt+ terminal (TB2 pin6) to the PBatt+ terminal (TB1 pin1).

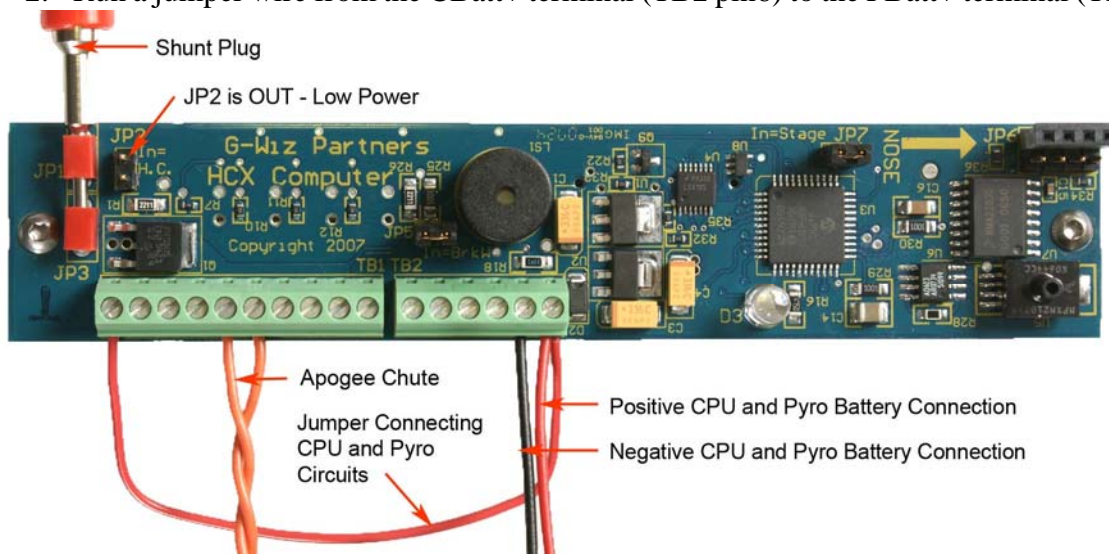

To Test the Setup

After all the devices are hooked up, you can test the system. Make sure the shunt plug is correctly installed and then power the HCX on. The beeper will:

1. *Emit two quick beeps. – The battery is OK and the Cluster/Stage jumper JP7 is set to stage mode.*
2. *Emit two beeps. – Nothing is connected to the Cluster/Stage terminals.*
3. *Emit one beep. - The Apogee firing device has continuity.*
4. *Emit two beeps. – Nothing is connected to the Low Altitude terminals.*
5. *Emit two beeps. – Nothing is connected to the Programmable terminals.*
6. *Then it will pause and cycle the beep pattern again.*

If this is not the pattern you hear, refer to Appendix B for a list of the status codes.

To Configure your Flight Computer

1. Connect your flight computer to your personal computer.
 - o See the instructions for connecting the flight computer in the [Using FlightView Software](#) section of the [User Manual](#).
2. Go into the **Configuration** menu.
3. On the **Main** and **Output** tabs, change the configuration settings to match your flight plan.
 - o If you have any problems, consult the [Configuring your HCX section](#) in the [Using FlightView Software](#) chapter of the [User Manual](#).
4. Select **Upload and Exit**.
5. Disconnect your flight computer from your personal computer.
6. Power your flight computer off and then on to load the new configuration into memory.

Once you've tested your setup by listening to the beep sequence and observing the status LED, you can either leave it on or turn it off until the rocket is mounted on the pad. The launch sensor is pretty robust and the shunt plug will not allow the charges to fire.

Important: Do not remove the red shunt plug from JP1/3 until the rocket is mounted on the pad and ready to launch or until you power it off.

Cluster Ignition, Single Parachute Deployment at Apogee Using Two Batteries

One battery powers the computer and the other powers the Pyro Ports.

In the Cluster mode the unit fires the cluster motor (or motors) as soon as it detects and confirms launch. This occurs approximately 0.5 seconds after the first movement of the rocket. There is also a delay factor from the time the igniter fires until the time the motor (or motors) actually ignite. See your motor manufacturer for more information on this delay.

To Set Up the On-Board Hardware

1. Install a shunt plug into the safety shunt JP1/3.
2. Install your SD card in its socket.
3. Make sure the small JP2 jumper connector, located next to the shunt plug, is **IN**.



4. Pull the small jumper connector off the JP7 twin pin jumper.

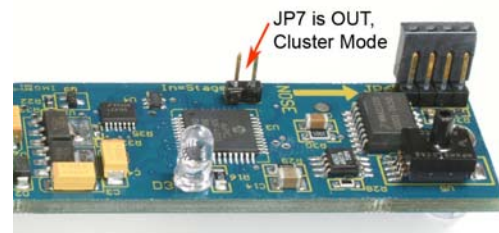

Your flight computer is now enabled up for high pyro current, which is required when you use the HCX for any flight involving staging or clustering.

To Wire the Pyro Ports

1. Wire your main chute firing device to the **Apogee** terminals (TB1 pins 5/6).
2. Wire your cluster-motor firing device to the **Cluster/Stage** terminals (TB1 pins 3/4).

To Wire Up Your Power Connection

1. Wire a 9 volt battery for the computer to the CBatt terminals (TB2 pins 5/6) making sure your polarity is correct.
2. Wire a second battery, in the 9 to 15 volts range, for the pyro ports. Attach it to the PBatt terminals (TB1 pin 1/2) making sure your polarity is correct.

To Test the Setup

After all the devices are hooked up, you can test the system. Make sure the shunt plug is correctly installed and then power the HCX on. The beeper will:

1. Emit one long beep. – The battery is OK and the Cluster/Stage jumper JP7 is set to Cluster mode.
2. Emit one beep. – The Cluster/Stage firing device has continuity.
3. Emit one beep. - The Apogee firing device has continuity.
4. Emit two beeps. – Nothing is connected to the Low Altitude terminals.

5. *Emit two beeps. – Nothing is connected to the Programmable terminals.*
6. *Then it will pause and cycle the beep pattern again.*

If this is not the pattern you hear, refer to [Appendix B](#) for a list of the Flight Computer Status codes.

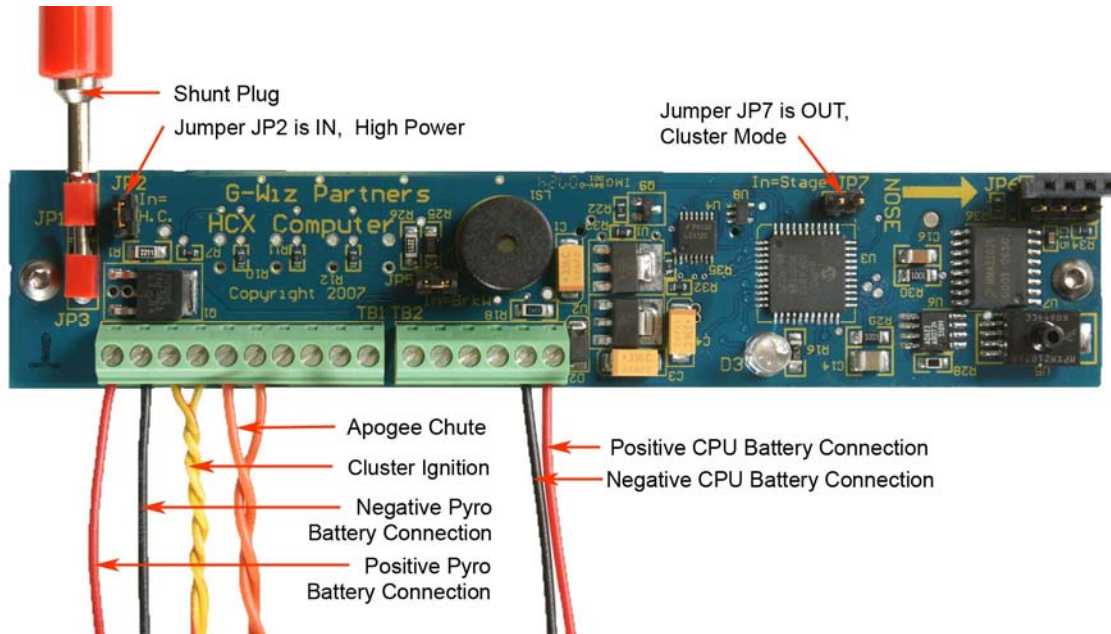

To Configure your Flight Computer

1. Connect your flight computer to your personal computer.
 - o See the instructions for connecting the flight computer in the [Using FlightView Software](#) section of the [User Manual](#).
2. Go into the **Configuration** menu.
3. On the **Main** and **Output** tabs, change the configuration settings to match your flight plan.
 - o If you have any problems, consult the [Configuring your HCX](#) section in the [Using FlightView Software](#) chapter of the [User Manual](#).
4. Select **Upload and Exit**.
5. Disconnect your flight computer from your personal computer.
6. Power your flight computer off and then on to load the new configuration into memory.

Once you've tested your setup by listening to the beep sequence and observing the status LED, you can either leave it on or turn it off until the rocket is mounted on the pad. The launch sensor is pretty robust and the shunt plug will not allow the charges to fire.

Important: Do not remove the red shunt plug from JP1/3 until the rocket is mounted on the pad and ready to launch or until you power it off.

Appendix A – Product Specifications

Parameter	HCX-50G	HCX-100G	HCX-200G
Maximum acceleration	+/- 56 g	+/- 112 g	+/- 225 g
Maximum inertial altitude (32-bit math)	100K+ feet MSL ¹		
Maximum barometric altitude (Limited by sensor linearity)	70K feet MSL		
Number of pyro channels	Four		
Maximum continuous current (Per pyro channel)	7 Amps		
Number of batteries required	One or Two (We strongly recommend using 2 batteries)		
Recommended computer battery	9 VDC transistor battery (Duracell MN1604)		
Maximum voltage applied to computer battery input terminals (TB 2 pins 9/10)	12 VDC		
Computer current consumption	65mA typical at idle		
Maximum voltage applied to pyro battery input terminals (TB 1 pins 1/2)	15 VDC		
Pyro channel test current (9VDC battery)	3.5mA		
Pyro channel firing time	Programmable		
Pyro channel functions	1: Stage/cluster 2: Apogee parachute deployment (typical) 3: Low altitude parachute deployment (typical) 4: User Selectable/Programmable		
Low altitude pyro channel activation	Programmable (Default is 800 feet)		
ADC resolution	12-bits or 1.22 mV/bit		
Analog Input Channel: Range / Resolution	Input Range = 0 to 5.0 VDC Resolution = 12-bits or 1.22 mV/bit		
Breakwire Input Switch Requirements	Closed – to – open signals launch		
Sensor Sample Rate	Selectable – 66.67 to 500 samples per second		
Altitude readout	Status LED and acoustic beeper (Reads out barometric altitude)		
User field interface	1 Status LED 1 Beeper		
Data recording depth	Limited only by the size, in MB or GB, of the Mini-SD card used (2Gigabyte Maximum card size)		
Host computer interface	TTL/CMOS Serial (Use the G-Wiz USB or RS 232 adapter to interface to a host computer)		
Main battery life (With separate pyro battery)	6 Hours (typical)		
Weight (typical)	45 g	51 g	51 g
Operating Temperature Range	0-85°C		

¹ Flights over 25,000 feet MSL require HCX to be coated with a special epoxy layer. The coating protects the circuit board and components from condensing moisture. This also insures proper electrical operation of HCX. Please contact G-Wiz Partners for special order options.

Appendix B – Flight Computer Status Codes

These status codes are listed by how frequently they are heard. The Normal sequence is listed first and then the error code sequences, 1) low battery, 2) unplugged SD card, 3) breakwire error and 4) power-on self-test failure.

Normal Status Code

1. LED turns on then off.
2. The LED turns on and the beeper gives one (JP7 OUT) or two (JP7 IN) low pitch beeps.
3. LED turns off.
4. There is a half second pause.
5. Starting with pyro port one, each pyro port reports status with either a single quick “beep” (for good continuity) or a double “beep” if the port has incomplete continuity.
6. A one second pause, and then the sequence repeats from step 2.

Non-Fatal Error Status Codes

Low Battery

1. LED turns on, then off.
2. The LED turns on and the beeper gives one (JP7 OUT) or two (JP7 IN) low pitch beeps.
3. After a half second pause, the beeper gives a short warble.
4. LED turns off.
5. There is a half second pause.
6. Starting with pyro port one, each pyro port reports status with either a single quick “beep” (for good continuity) or a double “beep” if the port has incomplete continuity.
7. A 1 second pause, and then the sequence repeats from step 2.

If you hear this sequence, you have less than sixty minutes before your batteries die. If possible, change your batteries to avoid losing power during your flight.. If this is not possible, for example, because your rocket is already assembled and on the pad, ask the LCO to expedite your launch.

SD Card is Unplugged

1. The LED turns on then off.
2. Long, High pitch beep.
3. Long, low pitch beep.
4. A 3/4 second pause.
5. Normal status code starts.

While you can still fly without the SD Card installed, your flight computer will have no means of recording the flight data.

The flight computer will still be able to fire all events and your maximum altitude will beep out after landing.

Fatal Error Status Codes

Break Wire Error

The unit is configured for a breakwire launch but the break wire is not connected.

1. *Short warble.*
2. *A 1 second pause, and then the sequence repeats.*

Warning: If you hear this sequence, you will not be able fly your rocket until the error is corrected. Follow these instructions to correct the problem.

To Correct the Setup, If You Want a Breakwire Flight

1. Power your unit off.
2. Connect your break wire.
3. Power your unit on to continue.

To Correct the Setup, If the Breakwire Mode was Configured by Mistake

1. Power your unit off.
2. Attach a wire between the two Breakwire terminals (TB2 pins 3/4).
3. Connect your flight computer to FlightView.
4. Go into the Configuration screen.
5. Uncheck the Breakwire Launch Detect checkbox.
6. Disconnect from FlightView.
7. Power-cycle your flight computer to continue.

Power-On Self-Test Failure (POST Failure)

1. *Long warble.*
2. *Half second delay.*
3. *1 – 7 high pitch beeps giving a failure code.*
 - For 1 to 4 beeps see the Hardware Error chart.
 - For 5 beeps, there will be an additional set of lower pitched beeps. Count these beeps and see the Initialization Error chart.
 - For 6 beeps, there will be an additional set of lower pitched beeps. Count these beeps and see the File Creation Error chart.
 - For 7 beeps, the SD card is full.
4. *A 1 second pause, and then the sequence repeats.*

POST Failure Code Lookup Charts

Hardware Error Chart - First Set of Beeps (High Pitch)

Beep Code	Problem	Solution
1 beep	Failure reading configuration from EEPROM	Do not fly – Contact G-Wiz
2 beeps	Sensors reading out of range	Do not fly – Contact G-Wiz
3 beeps	Accelerometer self-test failure	Do not fly – Contact G-Wiz
4 beeps	Accelerometer status failure	Do not fly – Contact G-Wiz
5 beeps	SD Card initialization error – Secondary code will beep.	Count the low pitched beeps and refer to the Initialization Error chart.
6 beeps	SD file-creation error – Secondary code will beep.	Count the low pitched beeps and refer to the File Creation Error chart.
7 beeps	SD file-creation	Not enough space available on the card. Reformat or replace card.

Card Initialization Error Chart – Second Set- Block 1 (Low Pitch)

Beep Code	Problem	Solution
1 beep	Failure to reset card.	Reformat or replace card.
2 beeps	Failure to initialize card.	Reformat or replace card.
3 beeps	Wrong file system on card.	Reformat card as FAT or FAT32.
4 beeps	SD card read error.	Probable cause: bad card.
5 beeps	SD card not FAT formatted.	Reformat card as FAT or FAT32.
6 beeps	SD card partition table bad.	Reformat card as FAT or FAT32.
7 beeps	SD card partition not right type.	Reformat card as FAT or FAT32.
8 beeps	SD card read error.	Probable cause: bad card.
9 beeps	SD card not properly formatted.	Reformat card as FAT or FAT32.
10 beeps	SD card, bad sector size.	Reformat card with 512 byte sectors
11 beeps	SD card formatted as FAT12.	Unsupported configuration – Reformat card as FAT or FAT32.

Card File Creation Error Chart – Second Set-Block 2 (Low pitch)

Beep Code	Problem	Solution
1 beep	File creation error 1.	Do not fly – Contact G-Wiz.
2 beeps	SD card full.	Try a newly formatted card.
3 beeps	SD card write error.	Try a different card.
4 beeps	SD card directory error.	Try a different card.

Unless the failure is due to a SD card problem that can be remedied by changing cards, POST failures should be reported to G-Wiz support (support@gwiz-partners.com). You should not fly the flight computer.

Appendix C – Mechanical Drawing

When you design your flight computer’s mounting system, here are the important dimensions you need to know.

G-Wiz HCX Flight Computer Mechanical Dimensions

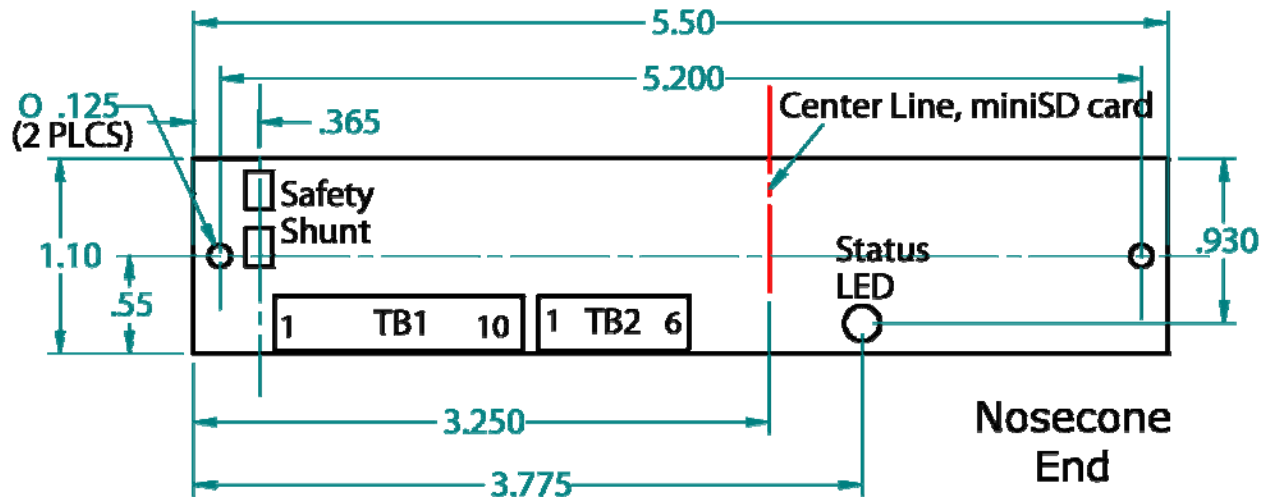

HCX is supplied with standoffs that support #4-40 machine screws.

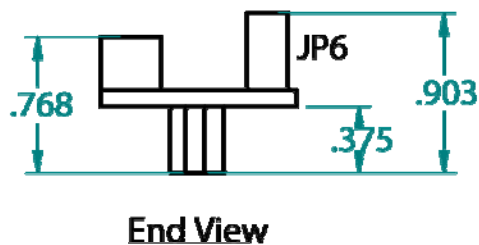

Appendix D –Installing USB Drivers on Macintosh

Installing the USB drivers on the Mac is a bit complex.

First, make sure you have FlightView 2.8 or later. If not, download the most recent version from our web-site at www.gwiz-partners.com.

Note: You must have administrator privileges to install these drivers.

These instructions may not be applicable to newer Macs.

To Install the USB Drivers on a Macintosh

1. Open the folder where FlightView was installed.
 - o This is usually **Applications/GwizViewer**.
2. Double-click the package icon named **FTDIUSBSerialDriver**.
3. In your **Utilities** folder, open the **Terminal** program.
4. At the prompt, type: `cd /Library/StartupItems/FTDIReEnumerate` and press RETURN.
5. Type `sudo pico FTDIReEnumerate` and press RETURN.
6. Type in your administrator password when requested by the system.
7. Find this line in the terminal editor window:
`/Library/StartupItems/FTDIReEnumerate/ReEnumerate -v0403 -p6001`
8. Replace it with these two lines:
`/Library/StartupItems/FTDIReEnumerate/ReEnumerate -v0403 -pEE18`
`/Library/StartupItems/FTDIReEnumerate/ReEnumerate -v0403 -pDA38`
9. Save the file.
10. Exit the editor.
11. Exit Terminal.
12. Restart the Macintosh.

You should now be able to connect to HCX using USB.

Appendix F – Installing USB Drivers on Windows XP

Windows XP seems to be harder for people to install our drivers on, so here is a guided tour.

1. Log into your PC as an administrator before connecting the interface card for the first time.
2. Connect your USB interface card.
 - o Windows XP will display this dialog box:



3. Select **No, not this time**, and press “**Next**”.
 - o Windows XP will now display:

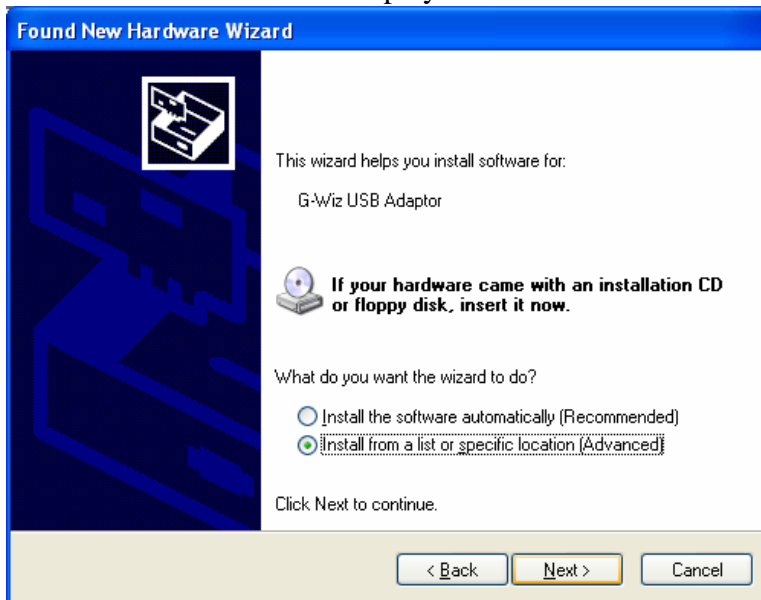

4. Select **Install from a list or specific location (Advanced)**, and click **Next**.
 - o Windows will now display this dialog box:

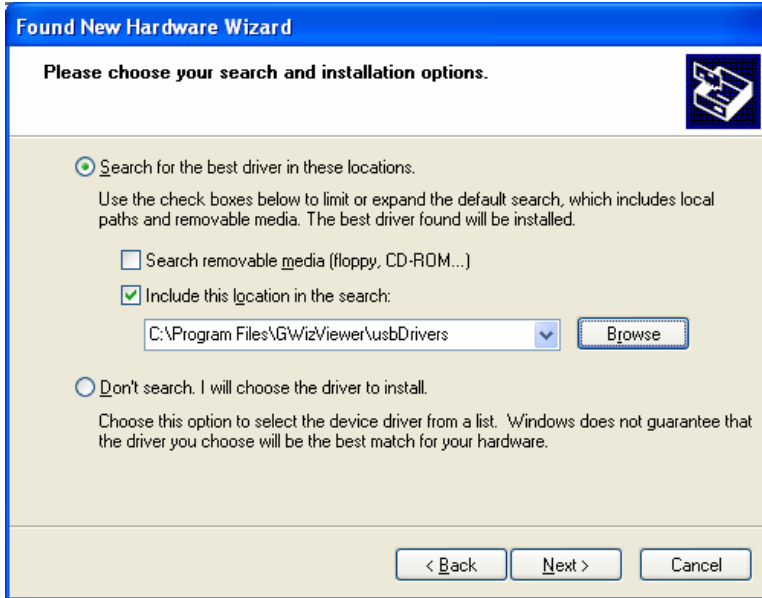

5. Select the **Search for the best driver in these locations** and the **Include this location in the search** checkboxes.
6. De-select the Search removable media checkbox.
7. In the edit field, browse to, or type in, the location of the GWizViewer install directory, and then navigate to the **usbDrivers** directory under it.
 - o The location shown here is the default installation directory, if your main disk is 'C'.
8. Click **Next**.
 - o Windows XP will display this dialog box:



9. Press the **Continue Anyway** button to continue the installation.
10. Repeat steps 1 through 8 for the second driver.

Your computer is now ready to connect from FlightView to your G-Wiz HCX flight computer through the G-Wiz USB Interface Card.

Appendix F – Installing USB Drivers on Windows Vista

Windows Vista is even less straightforward than XP for installing our drivers. Mainly this is because Microsoft is trying to make the process totally invisible to the user. Therefore, if you have anything unusual about an installation, Windows gets confused. This is a step by step tour of the process.

1. Log into your PC as an administrator before you connect the interface card to your PC for the first time.
2. Connect your USB interface card and cable to your PC.
 - o Windows Vista will display this dialog box:

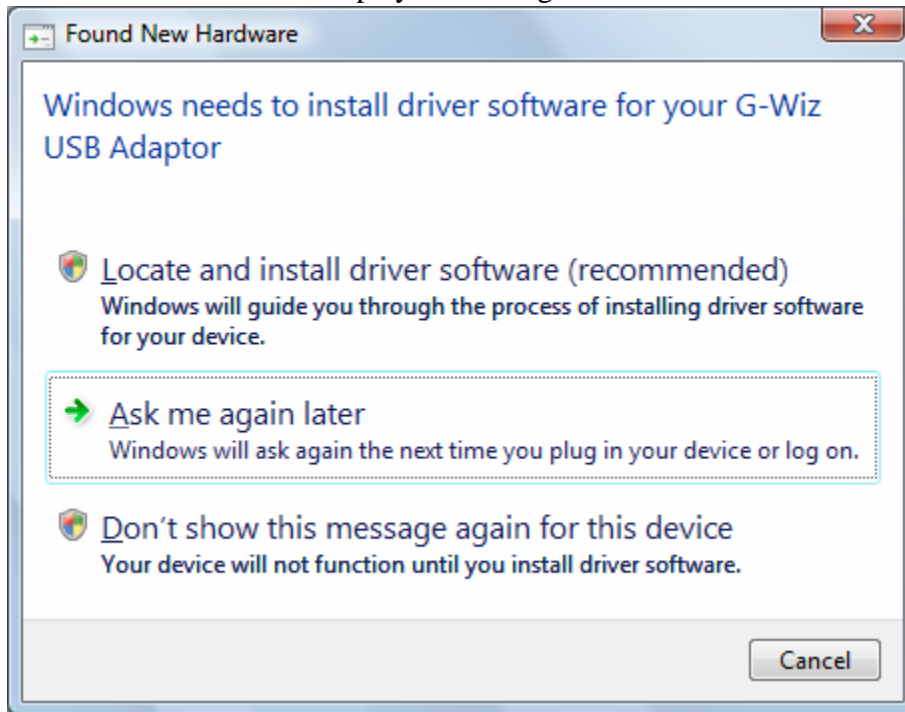

3. Select **Locate and install driver software**.
 - o If you select **Ask me again later**, the installation will stop. Unplug the USB card and then plug it back in to restart the installation process.

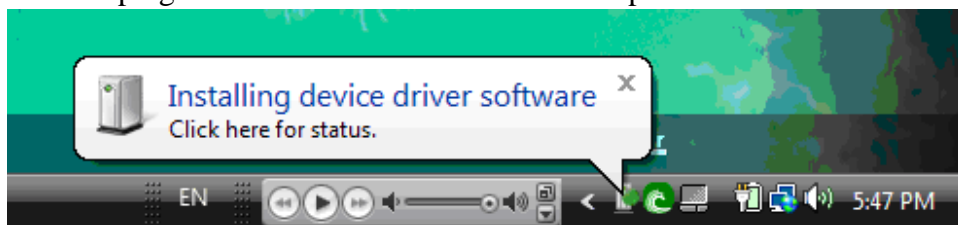

- Windows will start by looking for drivers in Windows Update. There is no way to tell it not to do so. If you click on the Device Installation icon in the notification area of the taskbar you will see this progress window.

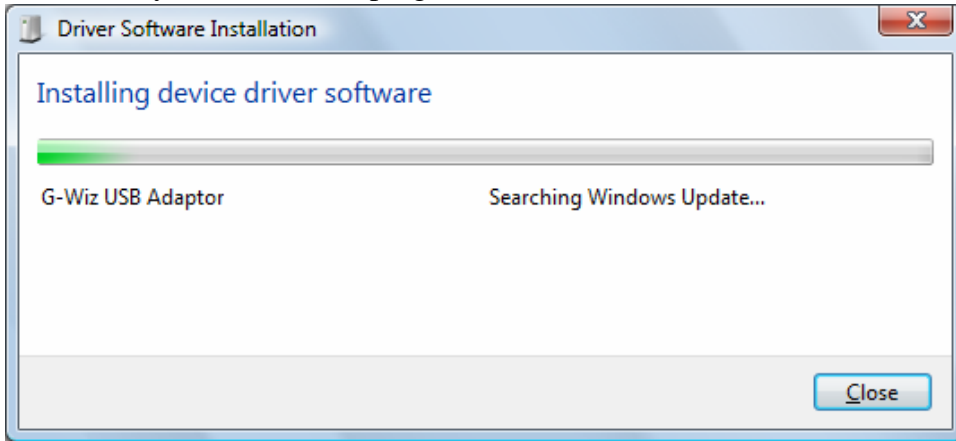

4. **Do not close this window.**

- After searching for a few minutes, Windows will display:

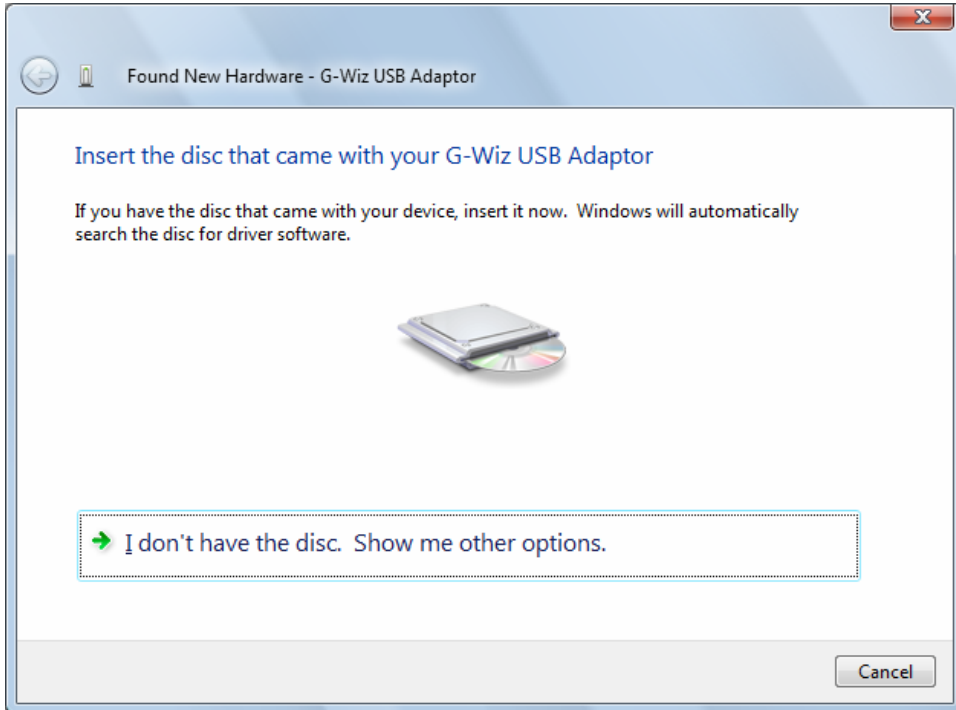

5. Click **I don't have the disc. Show me other options.**

- Windows will now display:

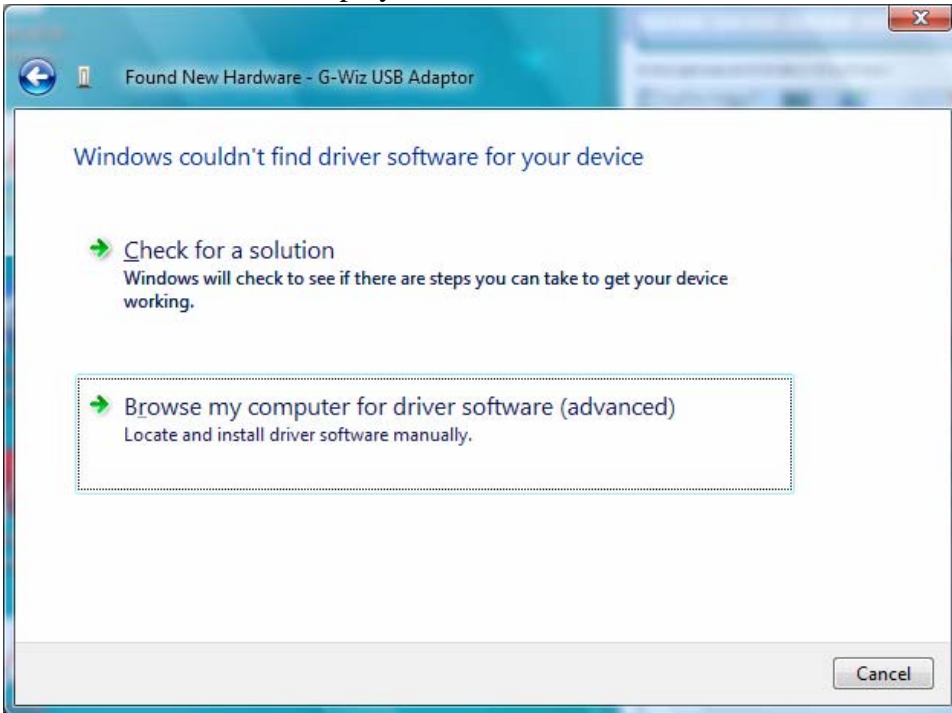

6. Click **Browse my computer for driver software (advanced).**

- Windows will now open a file browser dialog box:

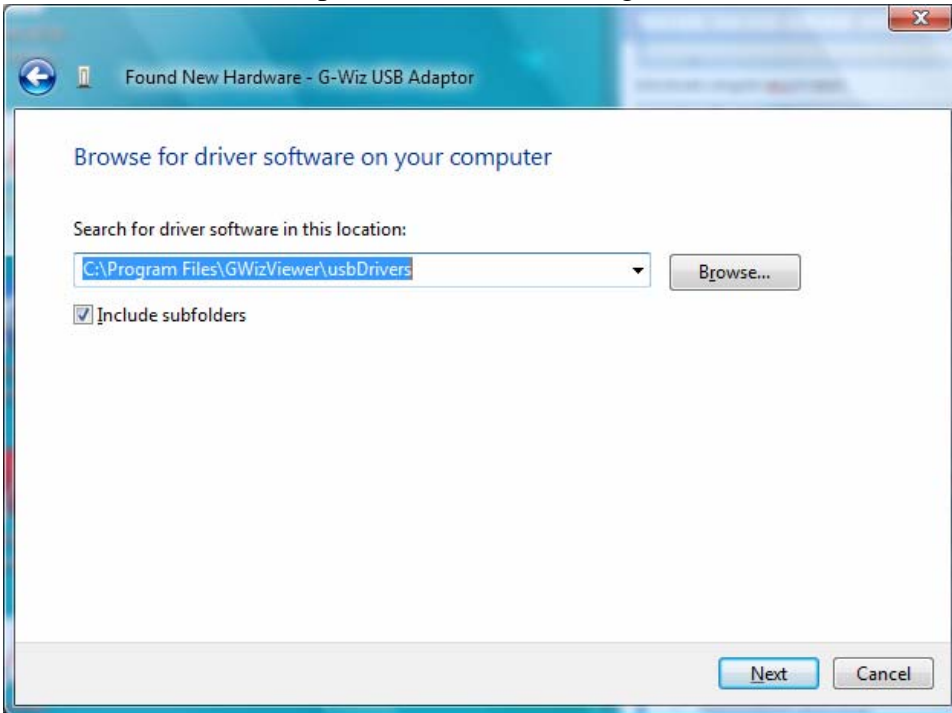

7. Navigate to the directory where you installed **GWizFlightView**, and then to the **usbDrivers** directory under it.

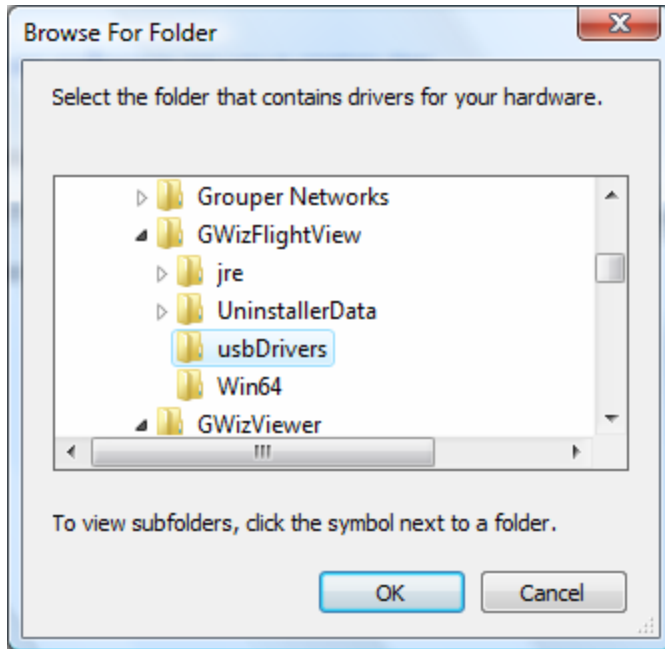

8. Select the **usbDrivers** directory and click **OK**.
9. Click **OK** and Windows Vista will start to install the drivers.
 - o Windows will display

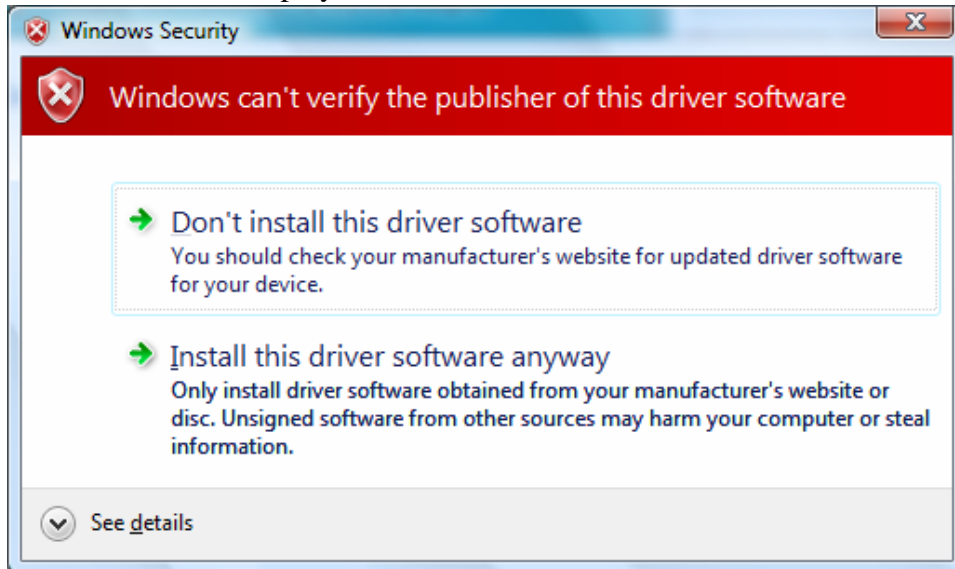

10. Click **Install this Driver Anyway**.
 - o When Windows tells you it has finished installing the drivers for the G-Wiz USB Interface Card, it will then tell you it has found a second device that needs a driver.

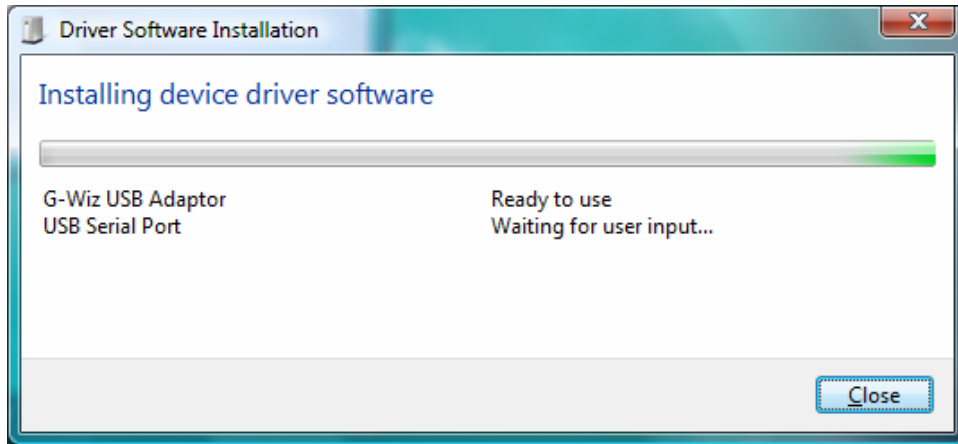

11. Repeat this process for the second driver.

Your computer is now ready to connect to your G-Wiz HCX flight computer through FlightView.

If, after reading this manual, you have any questions or problems with either your flight computer or the FlightView software, please visit us on the web at: <http://www.gwiz-partners.com>. We maintain an FAQ on our web site. In addition, the latest versions of both FlightView and the HCX Firmware are posted there for download.

You can email us at:

support@gwiz-partners.com

Or write us at:

G-Wiz Partners
PO Box 320103
Los Gatos, CA 95032-0101